



SRI MANAKULA VINAYAGAR ENGINEERING COLLEGE

(Approved by AICTE, New Delhi & Affiliated to Pondicherry University)
(Accredited by NBA-AICTE, New Delhi, ISO 9001:2000 Certified Institution & Accredited by NAAC with "A" Grade)



Madagadipet, Puducherry - 605 107

Future Smart Grid:

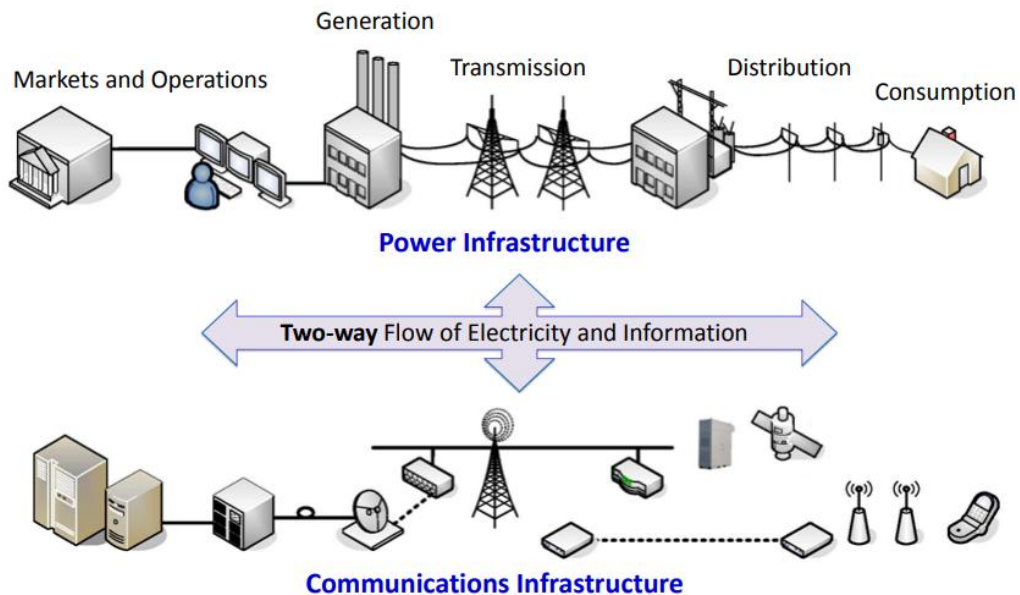

EE E19 SMART GRID

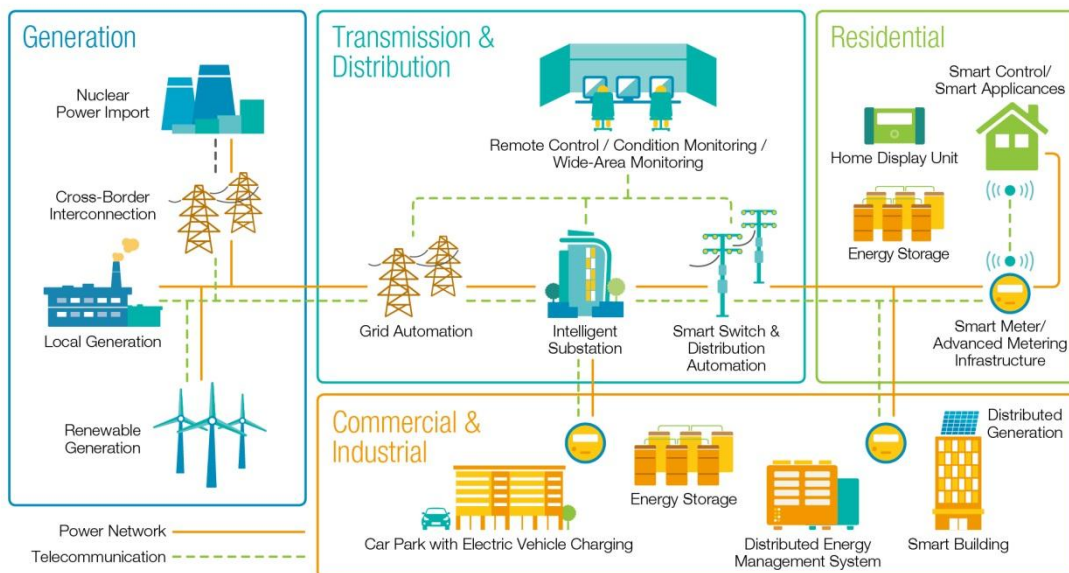

Department of Electrical and Electronics Engineering

Table of Content

SMART GRID

UNIT	CONTENT	PAGE NO.
I	INTRODUCTION TO SMART GRID	
II	WIDE AREA MONITORING SYSTEM	
III	SMART METERS	
IV	INFORMATION AND COMMUNICATION TECHNOLOGY	
V	SMART GRID APPLICATIONS	

EE E19 SMART GRID

Objective: The course content is designed to study about smart grid technologies, different smart meters and advanced metering infrastructure. It is used to get familiarized with power quality management and communication protocols for the smart grid applications.

UNIT I: INTRODUCTION TO SMART GRID

Evolution of Electric Grid–Need for smart grid– Difference between conventional & smart grid
– Overview of enabling technologies–International experience in smart grid deployment efforts– Smart grid road map for INDIA– smart grid architecture

UNIT II: WIDE AREA MONITORING SYSTEM

Fundamentals of synchro phasor technology – concept and benefits of wide area monitoring system– Structure and functions of Phasor Measuring Unit (PMU) and Phasor Data Concentrator (PDC)–Road Map for synchro phasor applications (NAPSI)–Operational experience and Blackout analysis using PMU

UNIT III: SMART METERS

Features and functions of smart meters– Functional specification–category of smart meters– AMR and AMI drivers and benefits– AMI protocol– Demand Side Integration–Peak load, Outage and Power Quality management

UNIT IV: INFORMATION AND COMMUNICATION TECHNOLOGY

Overview of smart grid communication system– Modulation and Demodulation techniques– Radio communication–Mobile communication–Power line communication– Optical fibre communication – Communication protocol for smart grid

UNIT V: SMART GRID APPLICATIONS

Overview and concept of renewable integration – role of protective relaying in smart grid– House Area Network– Advanced Energy Storage Technology - Flow battery– Fuel cell–SMES–Super capacitors– Plug-in Hybrid electric Vehicles– Cyber Security requirements–Smart grid information model

Total : 45 hours

REFERENCES

1. “Smart Grid Technology and Applications” by Janaka Ekanayake, Kithsiri Liyanage, Jianzhong Wu, Akihiko Yokoyama, Nick Jenkins, John Wiley & Sons Publication, 2012.
2. “Smart Grid Primer”, Published by Power Grid Corporation of India Limited, September 2013.
3. “Smart grid – integrating renewable, distributed and efficient energy”, Fereidoon.P.sioshansi, Academic Press, 2011.
4. “Smart Grids: Infrastructure, Technology and Solutions “Edited by Stuart Borlase,CRC Press Publication, 2013.

UNIT I: INTRODUCTION TO SMART GRID

**Evolution of Electric Grid–Need for smart grid– Difference between conventional & smart grid
– Overview of enabling technologies–International experience in smart grid deployment
efforts– Smart grid road map for INDIA– smart grid architecture**

Evolution of the Electricity Grid

The first **alternating current power grid** system was installed in 1886 in **Great Barrington, Massachusetts**. At that time, the grid was a centralized unidirectional system of **electric power transmission, electricity distribution**, and demand-driven control.

In the 20th century local grids grew over time, and were eventually interconnected for economic and reliability reasons. By the 1960s, the electric grids of developed countries had become very large, mature and highly interconnected, with thousands of 'central' generation power stations delivering power to major load centres via high capacity power lines which were then branched and divided to provide power to smaller industrial and domestic users over the entire supply area. The topology of the 1960s grid was a result of the strong economies of scale: large coal-, gas- and oil-fired power stations in the 1 GW (1000 MW) to 3 GW scale are still found to be cost-effective, due to efficiency-boosting features that can be cost effective only when the stations become very large.

Power stations were located strategically to be close to fossil fuel reserves (either the mines or wells themselves, or else close to rail, road or port supply lines). Siting of hydro-electric dams in mountain areas also strongly influenced the structure of the emerging grid. Nuclear power plants were sited for availability of cooling water. Finally, **fossil fuel**-fired power stations were initially very polluting and were sited as far as economically possible from population centres once electricity distribution networks permitted it. By the late 1960s, the electricity grid reached the overwhelming majority of the population of developed countries, with only outlying regional areas remaining 'off-grid'.

Metering of electricity consumption was necessary on a per-user basis in order to allow appropriate billing according to the (highly variable) level of consumption of different users. Because of limited data collection and processing capability during the period of growth of the grid, fixed-tariff arrangements were commonly put in place, as well as dual-tariff arrangements where night-time power was charged at a lower rate than daytime power. The motivation for dual-tariff arrangements was the lower night-time demand. Dual tariffs made possible the use of low-cost night-time electrical power in applications such as the maintaining of 'heat banks' which served to 'smooth out' the daily demand, and reduce the number of turbines that needed to be turned off overnight, thereby improving the utilisation and profitability of the generation and transmission facilities. The metering capabilities of the 1960s grid meant technological limitations on the degree to which price signals could be propagated through the system.

Through the 1970s to the 1990s, growing demand led to increasing numbers of power stations. In some areas, supply of electricity, especially at peak times, could not keep up with this demand, resulting in poor **power quality** including **blackouts**, power cuts, and **brownouts**. Increasingly, electricity was depended on for industry, heating, communication, lighting, and entertainment, and consumers demanded ever higher levels of reliability.

Towards the end of the 20th century, electricity demand patterns were established: domestic heating and air-conditioning led to daily peaks in demand that were met by an array of 'peaking power generators' that would only be turned on for short periods each day. The relatively low utilisation of these peaking generators (commonly, gas turbines were used due to their relatively lower capital cost and faster start-up times), together with the necessary redundancy in the electricity grid, resulted in high costs to the electricity companies, which were passed on in the form of increased tariffs. In the 21st century, some developing countries like China, India and Brazil were seen as pioneers of smart grid deployment.

Modernization opportunities

Since the early 21st century, opportunities to take advantage of improvements in electronic communication technology to resolve the limitations and costs of the electrical grid have become apparent. Technological limitations on metering no longer force peak power prices

to be averaged out and passed on to all consumers equally. In parallel, growing concerns over environmental damage from fossil-fired power stations has led to a desire to use large amounts of **renewable energy**. Dominant forms such as **wind power** and **solar power** are highly variable, and so the need for more sophisticated control systems became apparent, to facilitate the connection of sources to the otherwise highly controllable grid. Power from **photovoltaic cells** (and to a lesser extent **wind turbines**) has also, significantly, called into question the imperative for large, centralised power stations. The rapidly falling costs point to a major change from the centralised grid topology to one that is highly distributed, with power being both generated *and* consumed right at the limits of the grid. Finally, growing concern over **terrorist** attack in some countries has led to calls for a more robust energy grid that is less dependent on centralised power stations that were perceived to be potential attack targets.

Evolution of "Smart Grid"

The first official definition of Smart Grid was provided by the **Energy Independence and Security Act of 2007 (EISA-2007)**, which was approved by the US Congress in January 2007, and signed to law by **President George W. Bush** in December 2007. Title XIII of this bill provides a description, with ten characteristics, that can be considered a definition for Smart Grid, as follows:

"It is the policy of the United States to support the modernization of the Nation's electricity transmission and distribution system to maintain a reliable and secure electricity infrastructure that can meet future demand growth"

To achieve each of the following, which together characterize a Smart Grid:

- (1) Increased use of digital information and controls technology to improve reliability, security, and efficiency of the electric grid.
- (2) Dynamic optimization of grid operations and resources, with full cyber-security.
- (3) Deployment and integration of distributed resources and generation, including renewable resources.
- (4) Development and incorporation of demand response, demand-side resources, and energy-efficiency resources.

(5) Deployment of `smart' technologies (real-time, automated, interactive technologies that optimize the physical operation of appliances and consumer devices) for metering, communications concerning grid operations and status, and distribution automation.

(6) Integration of `smart' appliances and consumer devices.

(7) Deployment and integration of advanced electricity storage and peak-shaving technologies, including plug-in electric and hybrid electric vehicles, and thermal storage air conditioning.

(8) Provision to consumers of timely information and control options.

(9) Development of standards for communication and interoperability of appliances and equipment connected to the electric grid, including the infrastructure serving the grid.

(10) Identification and lowering of unreasonable or unnecessary barriers to adoption of smart grid technologies, practices, and services."

A common element to most definitions is the application of digital processing and communications to the power grid, making data flow and **information management** central to the smart grid. Various capabilities result from the deeply integrated use of digital technology with power grids. Integration of the new grid information is one of the key issues in the design of smart grids. Electric utilities now find themselves making three classes of transformations: improvement of infrastructure, called the *strong grid* in China; addition of the digital layer, which is the essence of the *smart grid*; and business process transformation, necessary to capitalize on the investments in smart technology. Much of the work that has been going on in electric grid modernization, especially substation and distribution automation, is now included in the general concept of the smart grid.

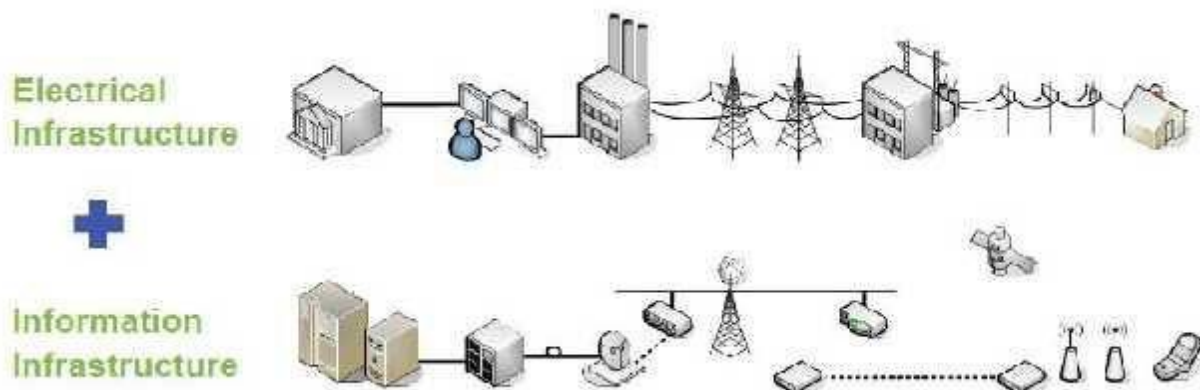



Early technological innovations

Smart grid technologies emerged from earlier attempts at using electronic control, metering, and monitoring. In the 1980s, **automatic meter reading** was used for monitoring loads from large customers, and evolved into the **Advanced Metering Infrastructure** of the 1990s, whose meters could store how electricity was used at different times of the day. **Smart meters** add continuous communications so that monitoring can be done in real time, and can be used as a gateway to **demand response**-aware devices and "smart sockets" in the home. Early forms of such **demand side management** technologies were **dynamic demand** aware devices that passively sensed the load on the grid by monitoring changes in the power supply frequency. Devices such as industrial and domestic air conditioners, refrigerators and heaters adjusted their duty cycle to avoid activation during times the grid was suffering a peak condition. Beginning in 2000, Italy's Telegestore Project was the first to network large numbers (27 million) of homes using smart meters connected via low bandwidth **power line communication**. Some experiments used the term **broadband over power lines (BPL)**, while others used wireless technologies such as **mesh networking** promoted for more reliable connections to disparate devices in the home as well as supporting metering of other utilities such as gas and water

Monitoring and synchronization of wide area networks were revolutionized in the early 1990s when the Bonneville Power Administration expanded its smart grid research with prototype sensors that are capable of very rapid analysis of anomalies in electricity quality over very large geographic areas. The culmination of this work was the first operational Wide Area

Measurement System (WAMS) in 2000. Other countries are rapidly integrating this technology. China started having a comprehensive national WAMS system when the past 5-year economic plan completed in 2012.

FEATURES OF THE SMART GRID

The smart grid represents the full suite of current and proposed responses to the challenges of electricity supply. Because of the diverse range of factors there are numerous competing taxonomies and no agreement on a universal definition. Nevertheless, one possible categorization is given here.

Reliability

The smart grid will make use of technologies, such as state estimation, that improve **fault detection** and allow **self-healing** of the network without the intervention of technicians. This will ensure more reliable supply of electricity, and reduced vulnerability to natural disasters or attack. The economic impact of improved grid reliability and resilience is the subject of a number of studies and can be calculated using a US DOE funded methodology for US locations using at least one calculation tool.

Flexibility in network topology

Next-generation transmission and distribution infrastructure will be better able to handle possible **bidirectional energy flows**, allowing for **distributed generation** such as from photovoltaic panels on building roofs, but also the use of fuel cells, charging to/from the batteries of electric cars, wind turbines, pumped hydroelectric power, and other sources.

Efficiency

Numerous contributions to overall improvement of the efficiency of energy infrastructure are anticipated from the deployment of smart grid technology, in particular including **demand-side management**. The overall effect is less redundancy in transmission and distribution lines, and greater utilization of generators, leading to lower power prices.

Load adjustment/Load balancing

The total load connected to the power grid can vary significantly over time. Although the total load is the sum of many individual choices of the clients, the overall load is not a stable, slow varying, increment of the load if a popular television program starts and millions of televisions will draw current instantly. Traditionally, to respond to a rapid increase in power consumption, faster than the start-up time of a large generator, some spare generators are put on a dissipative standby mode. A smart grid may warn all individual television sets, or another larger customer, to reduce the load temporarily (to allow time to start up a larger generator) or continuously (in the case of limited resources).

Peak curtailment/leveling and time of use pricing

To reduce demand during the high cost peak usage periods, communications and metering technologies inform smart devices in the home and business when energy demand is high and track how much electricity is used and when it is used. It also gives utility companies the ability to reduce consumption by communicating to devices directly in order to prevent system overloads. Examples would be a utility reducing the usage of a group of electric vehicle charging stations or shifting temperature set points of air conditioners in a city. To motivate them to cut back use and perform what is called **peak curtailment** or **peak leveling**, prices of electricity are increased during high demand periods, and decreased during low demand periods.

Sustainability

The improved flexibility of the smart grid permits greater penetration of highly variable renewable energy sources such as solar power and wind power, even without the addition of energy storage. Current network infrastructure is not built to allow for many distributed feed-in points, and typically even if some feed-in is allowed at the local (distribution) level, the transmission-level infrastructure cannot accommodate it. Rapid fluctuations in distributed generation, such as due to cloudy or gusty weather, present significant challenges to power engineers who need to ensure stable power levels through varying the output of the more controllable generators such as gas turbines and hydroelectric generators. Smart grid technology

is a necessary condition for very large amounts of renewable electricity on the grid for this reason.

Market-enabling

The smart grid allows for systematic communication between suppliers (their energy price) and consumers (their willingness-to-pay), and permits both the suppliers and the consumers to be more flexible and sophisticated in their operational strategies. Only the critical loads will need to pay the peak energy prices, and consumers will be able to be more strategic in when they use energy.

Demand response support

Demand response support allows generators and loads to interact in an automated fashion in real time, coordinating demand to flatten spikes. Eliminating the fraction of demand that occurs in these spikes eliminates the cost of adding reserve generators, cuts wear and tear and extends the life of equipment, and allows users to cut their energy bills by telling low priority devices to use energy only when it is cheapest. Demand response can be provided by commercial, residential loads, and industrial loads.

Latency of the data flow is a major concern, with some early smart meter architectures allowing actually as long as 24 hours delay in receiving the data, preventing any possible reaction by either supplying or demanding devices.

Platform for advanced services

As with other industries, use of robust two-way communications, advanced sensors, and distributed computing technology will improve the efficiency, reliability and safety of power delivery and use. It also opens up the potential for entirely new services or improvements on existing ones, such as fire monitoring and alarms that can shut off power, make phone calls to emergency services, etc.

NEED FOR SMART GRID

With a population of **over a billion people** and a current GDP growth rate of about **8 percent**, **India** is certainly one of the fastest growing countries in the world. Despite its robust economic growth, the country is still plagued by basic problems such as shortage of electricity, with nearly **40 percent** of its rural households having no access to electricity.

Although India has almost doubled its energy generation in the past decade by adding over **85 GW of capacity**, its grid systems lose **more than 30 GW** of this generated power. This is highly disturbing to people working in the power sector in India, who are concerned with the efficiency of the distribution of electricity.

The World Resources Institute estimates electricity transmission and distribution losses in India to be **27 percent** – the highest in the world. This is a huge wastage of one of the most environmentally unfriendly commodities to produce.

These insights lead Technavio to believe that India needs the help of new technology to ensure better monitoring and control of electricity transmission and distribution.

A Smart Grid is a digital electrical grid that facilitates the gathering and distribution of information with regard to the usage of power by suppliers and consumers. This will lead to electricity services becoming more reliable, efficient, cost-effective, and environmentally conscious.

Advantages of Smart Grid Technology

- Help businesses reduce their carbon footprint
- New opportunities for tech companies
- Reduce cost of power cuts
- Meet increasing demand for power supply in India

Why implement the Smart Grid now?

Since about 2005, there has been increasing interest in the Smart Grid. The recognition that ICT offers significant opportunities to modernise the operation of the electrical networks has

coincided with an understanding that the power sector can only be de-carbonized at a realistic cost if it is monitored and controlled effectively. In addition, a number of more detailed reasons have now coincided to stimulate interest in the Smart Grid.

1. Ageing assets and lack of circuit capacity

In many parts of the world (for example, the USA and most countries in Europe), the power system expanded rapidly from the 1950s and the transmission and distribution equipment that was installed then is now beyond its design life and in need of replacement. The capital costs of like-for-like replacement will be very high and it is even questionable if the required power equipment manufacturing capacity and the skilled staff are now available. The need to refurbish the transmission and distribution circuits is an obvious opportunity to innovate with new designs and operating practices.

In many countries the overhead line circuits, needed to meet load growth or to connect renewable generation, have been delayed for up to 10 years due to difficulties in obtaining rights-of-way and environmental permits. Therefore some of the existing power transmission and distribution lines are operating near their capacity and some renewable generation cannot be connected. This calls for more intelligent methods of increasing the power transfer capacity of circuits dynamically and rerouting the power flows through less loaded circuits.

2. Thermal constraints

Thermal constraints in existing transmission and distribution lines and equipment are the ultimate limit of their power transfer capability. When power equipment carries current in excess of its thermal rating, it becomes over-heated and its insulation deteriorates rapidly. This leads to a reduction in the life of the equipment and an increasing incidence of faults. If an overhead line passes too much current, the conductor lengthens, the sag of the catenary increases, and the clearance to the ground is reduced. Any reduction in the clearance of an overhead line to the ground has important consequences both for an increase in the number of faults but also as a danger to public safety. Thermal constraints depend on environmental conditions, that change through the year. Hence the use of dynamic ratings can increase circuit capacity at times.

3. Operational constraints

Any power system operates within prescribed voltage and frequency limits. If the voltage exceeds its upper limit, the insulation of components of the power system and consumer equipment may be damaged, leading to short-circuit faults. Too low a voltage may cause malfunctions of customer equipment and lead to excess current and tripping of some lines and generators. The capacity of many traditional distribution circuits is limited by the variations in voltage that occur between times of maximum and minimum load and so the circuits are not loaded near to their thermal limits. Although reduced loading of the circuits leads to low losses, it requires greater capital investment.

Renewable energy generation (for example, wind power, solar PV power) has a varying output which cannot be predicted with certainty hours ahead. A large central fossil-fuelled generator may require 6 hours to start up from cold. Some generators on the system (for example, a large nuclear plant) may operate at a constant output for either technical or commercial reasons. Thus maintaining the supply–demand balance and the system frequency within limits becomes difficult. Part-loaded generation ‘spinning reserve’ or energy storage can address this problem but with a consequent increase in cost. Therefore, power system operators increasingly are seeking frequency response and reserve services from the load demand. It is thought that in future the electrification of domestic heating loads (to reduce emissions of CO₂) and electric vehicle charging will lead to a greater capacity of flexible loads. This would help maintain network stability, reduce the requirement for reserve power from part-loaded generators and the need for network reinforcement.

4. Security of supply

Modern society requires an increasingly reliable electricity supply as more and more critical loads are connected. The traditional approach to improving reliability was to install additional redundant circuits, at considerable capital cost and environmental impact. Other than disconnecting the faulty circuit, no action was required to maintain supply after a fault. A Smart Grid approach is to use intelligent post-fault reconfiguration so that after the (inevitable) faults in the power system, the supplies to customers are maintained but to avoid the expense of multiple circuits that may be only partly loaded for much of their lives. Fewer redundant circuits result

in better utilization of assets but higher electrical losses.

5. National initiatives

Many national governments are encouraging Smart Grid initiatives as a cost-effective way to modernise their power system infrastructure while enabling the integration of low-carbon energy resources. Development of the Smart Grid is also seen in many countries as an important Economic/commercial opportunity to develop new products and services.

A lot has been done to mitigate the potential for blackouts—particularly in the effort to provide new technologies that can help make electricity more reliable, in order to sustain an increasingly high-tech economy which is based, in part, on the use of power-sensitive equipment. Many of these technologies are ready for wide deployment now, while others are only now entering demonstrations.

CONVENTIONAL GRID (TODAY 'S GRID) VERSUS THE SMART GRID

As mentioned, several factors contribute to the inability of today ' s grid to efficiently meet the demand for reliable power supply. Table compares the characteristics of today ' s grid with the preferred characteristics of the smart grid.

SL.No	Preferred Characteristics	Conventional Grid (or) Today ' s Grid	Smart Grid
1	Active Consumer Participation	Consumers are uninformed and do not participate	Informed, involved consumers —demand response and distributed energy resources
2	Accommodation of all generation and storage options	Dominated by central generation — many obstacles exist for distributed energy resources interconnection	Many distributed energy resources with plug - and - play convenience focus on renewables
3	New products, services, and markets	Limited, poorly integrated wholesale markets; limited opportunities for consumers	Mature, well - integrated wholesale markets; growth of new electricity markets for consumers
4	Provision of power quality for the digital economy	Focus on outages — slow response to power quality issues	Power quality a priority with a variety of quality/price options — rapid resolution of issues

5	Optimization of assets and operates efficiently	Little integration of operational data with asset management— business process silos	Greatly expanded data acquisition of grid parameters; focus on prevention, minimizing impact to consumers
6	Anticipating responses to system disturbances (self- healing)	Responds to prevent further damage; focus on protecting assets following a fault	Automatically detects and responds to problems; focus on prevention, minimizing impact to consumers
7	Resiliency against cyber attack and natural disasters	Vulnerable to malicious acts of terror and natural disasters; slow response	Resilient to cyber attack and natural disasters; rapid restoration capabilities

OVERVIEW OF ENABLING TECHNOLOGIES

Overview of the technologies required for the Smart Grid

To fulfill the different requirements of the Smart Grid, the following enabling technologies must be developed and implemented:

1. *Information and communications technologies:*

These include:

- (a) Two-way communication technologies to provide connectivity between different components in the power system and loads;
- (b) Open architectures for plug-and-play of home appliances; electric vehicles and micro generation;
- (c) Communications, and the necessary software and hardware to provide customers with greater information, enable customers to trade in energy markets and enable customers to provide demand-side response;
- (d) Software to ensure and maintain the security of information and standards to provide scalability and interoperability of information and communication systems.

2. *Sensing, measurement, control and automation technologies:*

These include:

- (a) Intelligent Electronic Devices (IED) to provide advanced protective relaying, measurements, fault records and event records for the power system;
- (b) Phasor Measurement Units (PMU) and Wide Area Monitoring, Protection and Control (WAMPAC) to ensure the security of the power system;

(c) Integrated sensors, measurements, control and automation systems and information and communication technologies to provide rapid diagnosis and timely response to any event in different parts of the power system.

(d) Smart appliances, communication, controls and monitors to maximise safety, comfort, convenience, and energy savings of homes;

(e) Smart meters, communication, displays and associated software to allow customers to have greater choice and control over electricity and gas use.

3. Power electronics and energy storage:

These include:

(a) High Voltage DC (HVDC) transmission and back-to-back schemes and Flexible AC Transmission Systems (FACTS) to enable long distance transport and integration of renewable energy sources;

(b) different power electronic interfaces and power electronic supporting devices to provide efficient connection of renewable energy sources and energy storage devices;

(c) series capacitors, Unified Power Flow Controllers (UPFC) and other FACTS devices to provide greater control over power flows in the AC grid;

(d) HVDC, FACTS and active filters together with integrated communication and control to ensure greater system flexibility, supply reliability and power quality;

(e) Power electronic interfaces and integrated communication and control to support system operations by controlling renewable energy sources, energy storage and consumer loads;

(f) Energy storage to facilitate greater flexibility and reliability of the power system.

(i) Wide Area Monitoring Systems (WAMS)

WAMS are designed by the utilities for optimal capacity of the transmission grid and to prevent the spread of disturbances. By providing real - time information on stability and operating safety margins, WAMS give early warnings of system disturbances for the prevention and mitigation of system - wide blackouts. WAMS utilize sensors distributed throughout the network in conjunction with GPS satellites for precise time stamping of measurements in the transmission system. The integrated sensors will interface with the communication network. Phasor Measurements are a current technology that is a component of most smart grid designs.

(ii) Phasor Measurement Units (PMU)

Phasor Measurement Units or Synchrophasors give operators a time - stamped snapshot of the power system. The PMUs consist of bus voltage phasors and branch current phasors, in addition to information such as locations and other network parameters. Phasor measurements are taken with high precision from different points of the power system at the same instant, allowing an operator to visualize the exact angular difference between different locations. PMUs are equipped with GPS receivers which allow synchronization of readings taken at distant points. Microprocessor – based instrumentation such as protection relays and Disturbance Fault Recorders (DFRs) incorporate the PMU module with other existing functionalities as an extended feature. The IEEE standard on Synchrophasors specifies the protocol for communicating the PMU data to the Phasor Data Concentrator. Figure illustrates the PMU measurement System

PMUs ensure voltage and current with high accuracy at a rate of 2.88 kHz. They can calculate real power, reactive power, frequency, and phase angle 12 times per 60 hertz cycle. The actual sampling rate used to achieve this output is 1.4 MHz . Recent trends now require fast controls and online implementations for mitigating voltage collapse in the shortest, least - cost time .

(iii) Smart Meters

Smart meters have two functions: providing data on energy usage to customers (end - users) to help control cost and consumption; sending data to the utility for load factor control, peak - load requirements, and the development of pricing strategies based on consumption information and so on Automated data reading is an additional component of both smart meters and two - way communication between customers and utilities. The development of smart meters is planned for electricity, water, and gas consumption.

Smart meters equip utility customers with knowledge about how much they pay per kilowatt hour and how and when they use energy. This will result in better pricing information and more accurate bills in addition to ensuring faster outage detection and restoration by the utility. Additional features will allow for demand - response rates, tax credits, tariff options, and participation in voluntary rewards programs for reduced consumption. Still other features will include remote connect/disconnect of users, appliance control and monitoring, smart thermostat, enhanced grid monitoring, switching, and prepaid metering.

(iv) Smart Appliances

Smart appliances cycle up and down in response to signals sent by the utility. The appliances enable customers to participate in voluntary demand response programs which award credits for limiting power use in peak demand periods or when the grid is under stress. An override function allows customers to control their appliances using the Internet.

Air conditioners, space heaters, water heaters, refrigerators, washers, and dryers represent about 20% of total electric demand during most of the day and throughout the year. Grid - friendly appliances use a simple computer chip that can sense disturbances in the grid ' s power frequency and can turn an appliance off for a few minutes to allow the grid to stabilize during a crisis.

(v) Advanced Metering Infrastructure (AMI)

AMI is the convergence of the grid, the communication infrastructure, and the supporting information infrastructure. The network - centric AMI coupled with the lack of a composite set of cross industry AMI security requirements and implementation guidance, is the primary motivation for its development. The problem domains to be addressed within AMI implementations are relatively new to the utility industry; however, precedence exists for implementing large - scale, network - centric solutions with high information assurance requirements. The defense, cable, and telecom industries offer many examples of requirements, standards, and best practices that are directly applicable to AMI implementations.

INTERNATIONAL EXPERIENCE IN SMART GRID DEPLOYMENT EFFORTS

INTERNATIONAL INITIATIVES

Many national governments are encouraging Smart Grid initiatives as a cost-effective way to modernise their power system infrastructure while enabling the integration of low-carbon energy resources. Development of the Smart Grid is also seen in many countries as an important Economic/commercial opportunity to develop new products and services. The major initiatives being in US, UK, Ireland, Italy, France, Germany, Spain, South Korea, Japan, Australia, Brazil and China. A summary of the major Smart Grid Initiatives worldwide is given ahead. Considering the benefits of Smart Grid implementation, it is also being implemented in India.

1. China

The Chinese government has declared that by 2020 the carbon emission per-unit of GDP will reduce to 40~45 per cent of that in 2008. Other drivers for developing the Smart Grid in China are the nation's rapid economic growth and the uneven geographical distribution of electricity generation and consumption.

The State Grid Corporation of China (SGCC) has released a medium–long term plan of the development of the Smart Grid. The SGCC interprets the Smart Grid as

“A strong and robust electric power system, which is backboneed with Ultra High Voltage (UHV) networks; based on the coordinated development of power grids at different voltage levels; supported by information and communication infrastructure; characterized as an automated, and interoperable power system and the integration of electricity, information, and business flows.”

2. The European Union

The SmartGrids Technology Platform of the European Union (EU) has published a vision and strategy for Europe's electricity networks of the future. It states:

“It is vital that Europe's electricity networks are able to integrate all low carbon generation technologies as well as to encourage the demand side to play an active part in the supply chain. This must be done by upgrading and evolving the networks efficiently and economically.”

The Smart Grids Technology Platform identified the following important areas as key challenges that impact on the delivery of the EU-mandated targets for the utilisation of renewable energy, efficiency and carbon reductions by 2020 and 2050:

- Strengthening the grid, including extending it offshore;
- Developing decentralized architectures for system control;
- Delivering communications infrastructure;
- Enabling an active demand side;
- Integrating intermittent generation;
- Enhancing the intelligence of generation, demand and the grid;

- Capturing the benefits of distributed generation (DG) and storage;
- Preparing for electric vehicles.

3. Japan

In 2009, the Japanese government declared that by 2020 carbon emissions from all sectors will be reduced to 75 per cent of those in 1990 or two-thirds of those in 2005. In order to achieve this target, 28 GW and 53 GW of photovoltaic (PV) generations are required to be installed in the power grid by 2020 and 2030. The mandate given to these committees was to discuss the following technical and regulatory issues regarding the large penetration of renewable energy, especially PV generation, into the power grid:

- Surplus power under light load conditions;
- Frequency fluctuations;
- Voltage rise on distribution lines;
- Priority interconnection, access and dispatching for renewable energy-based generators;
- Cost recovery for building the Smart Grid.

Since the Tohoku earthquake on 11 March 2011, the Smart Grid has been attracting much attention for the reconstruction of the damaged districts and the development of a low-carbon society.

4. The UK

The Department of Energy and Climate Change document *Smarter Grids: The Opportunity* states that the aim of developing the Smart Grid is to provide flexibility to the current electricity network, thus enabling a cost-effective and secure transition to a low-carbon energy system. The Smart Grid route map recognises a number of critical developments that will drive the UK electrical system towards a low carbon system. These include:

- Rapid expansion of intermittent renewables and less flexible nuclear generation in conjunction with the retirement of flexible coal generation;
- Electrification of heating and transport;
- Penetration of distributed energy resources which include distributed generation, demand response and storage;
- Increasing penetration of electric vehicles.

5. The USA

According to Public Law 110–140-DEC. 19, 2007 , the United States of America (the USA)

“Is supporting modernization of the electricity transmission and distribution networks to maintain a reliable and secure electricity infrastructure that can meet future demand growth and to achieve increased use of digital information and controls technology; dynamic optimization of grid operations and resources; deployment and integration of distributed resources and generation; development and incorporation of demand response, demand-side resources, and energy-efficient resources; development of ‘smart’ technologies for metering, communications and status, and distribution automation; integration of ‘smart’ appliances and consumer devices; deployment and integration of advanced electricity storage and peak-shaving technologies; provisions to consumers of timely information and control options and development of standards for communication and inter-operability.”

6. Spain

In 2008, the government mandated distribution companies to replace existing meters with new smart meters; this must be done at no additional cost to the customer. The utility Endesa aims to deploy automated meter management to more than 13 million customers on the low voltage network from 2010 to 2015, building on past efforts by the Italian utility ENEL. The communication protocol used will be open. The utility Iberdrola will replace 10 million meters.

7. Germany

The E-Energy funding programme has several projects focusing on ICTs for the energy system. 8.2.8. Australia The Australian government announced the AUD 100 million “Smart Grid, Smart City” initiative in 2009 to deliver a commercial-scale smart grid demonstration project. Additional efforts in the area of renewable energy deployments are resulting in further study on smart grids.

9. United Kingdom

The energy regulator OFGEM has an initiative called the Registered Power Zone that will encourage distributors to develop and implement innovative solutions to connect distributed generators to the network. OFGEM has set up a Low Carbon Networks fund that will allow up to GBP 500m support to DSO projects that test new technology, operating and commercial arrangements.

10. France

The electricity distribution operator ERDF is deploying 300 000 smart meters in a pilot project based on an advanced communication protocol named Linky. If the pilot is deemed a success, ERDF will replace all of its 35 million meters with Linky smart meters from 2012 to 2016.

11. India

India has already established the India Smart Grid Task Force & India Smart Grid Forum to develop the framework and national policy. In this regard roadmap for future activities has already been released. Govt. of India has approved 14 pilot projects across the country for demonstration of different functionalities. Govt. of India has projected an outlay of about Rs. 9500 Cr. for Smart Grid development during 12th plan period (2012-17).

POWERGRID has taken a leading initiative in developing Puducherry as pilot smart grid project through collaborative efforts. Around 57 organizations has joined their hands for the project, where different attributes of Smart grid are being implemented in a holistic manner.

ON-GOING SMART GRID ACTIVITIES

APDRP, R-APDRP initiative for distribution reform (AT&C focus)

DRUM India – Distribution Reform Upgrade, Management

Four Pilot Project Sites (North Delhi, Bangalore, Gujarat, Maharashtra)

KEPCO project in Kerala India - \$10 Billion initiative for Smart-Grid

L&T and Telvent project – Maharashtra – Distribution Management System roll-out

SMART GRID ROADMAP FOR INDIA

“Transform the Indian power sector into a secure, adaptive, sustainable and digitally enabled ecosystem that provides reliable and quality energy for all with active participation of stakeholders”

In order to achieve this vision, stakeholders are advised to formulate state/utility specific policies and programs in alignment with following broad policies and targets which are in line with MoP's overarching policy objective of Access, Availability and Affordability of Power for All:

A) Distribution (Including Distributed Generation)

1. Appropriate policies and programs to provide access to electricity for all with uninterrupted life line supply (8 hours/day minimum, including the evening peak) and electrification of 100% households by 2017 and continuous improvement in quality and quantum of supply.
2. Enabling programs and projects in distribution utilities to reduce AT&C losses to below 15% by 2017, below 12% by 2022, and below 10% by 2027.
3. Integrated technology trials through a set of smart grid pilot projects by 2015; and based on outcome of the pilots, full rollout of smart grids in pilot project areas by 2017; in major urban areas by 2022 and nationwide by 2027.
4. Modernization of distribution sub-stations and conversion of sub-stations in all urban areas (starting with metro cities) to Gas Insulated Substations based on techno-commercial feasibility in a phased manner through innovative financing models.
5. Development of Microgrids, storage options, virtual power plants (VPP), solar photovoltaic to grid (PV2G), and building to grid (B2G) technologies in order to manage peak demand, optimally use installed capacity and eliminate load shedding and black-outs.
6. Policies for mandatory roof top solar power generation for large establishments, i.e., with connected load more than 20kW or otherwise defined threshold.
7. Microgrids in 1000 villages/industrial parks/commercial hubs by 2017 and 10,000 villages /industrial parks/commercial hubs by 2022, which can island from the main grid during peak hours or grid disturbances.

B) Transmission

1. Development of a reliable, secure and resilient grid supported by a strong communication infrastructure that enables greater visibility and control of efficient power flow between all sources of production and consumption by 2027.

2. Implementation of Wide Area Monitoring Systems (WAMS, using Phasor Measurement Units, or PMUs) for the entire transmission system. Installation of a larger number of PMUs on the transmission network by 2017 or sooner, as guided by the results of initial deployments.\ Indigenization of WAMS technology and PMU development and development of custom made analytics for synchrophasor data by 2017.
3. Setting up of Renewable Energy Monitoring Centre's (REMCs) and Energy Storage Systems to facilitate grid integration of renewable generation.
4. 50,000 Kms of optical fiber cables to be installed over transmission lines by the year 2017 to support implementation of smart grid technologies.
5. Enabling programs and projects in transmission utilities to reduce transmission losses to below 4% by 2017 and below 3.5% by 2022.
6. Implement power system enhancements to facilitate evacuation and integration of 30 GW renewable capacity by 2017, 80 GW by 2022, and 130 GW by 2027 – or targets mutually agreed between Ministry of New and Renewable Energy (MNRE) and MoP.

C) Policies, Standards and Regulations

1. Formulation of effective customer outreach and communication programs for active involvement of consumers in the smart grid implementation.
2. Development of state/utility specific strategic roadmap(s) for implementation of smart grid technologies across the state/utility by 2014. Required business process reengineering, change management and capacity building programs to be initiated by 2014. State Regulators and utilities may take the lead here.
3. Finalization of frameworks for cyber security assessment, audit and certification of power utilities by end of 2013.
4. Policies for grid-interconnection of captive/consumer generation facilities (including renewables) where ever technically feasible; policies for roof-top solar, net-metering/feed-in tariff; and policies for peaking power stations by 2014.
5. Policies supporting improved tariffs such as dynamic tariffs, variable tariffs, etc., including mandatory demand response (DR) programs, starting with bulk consumers by 2014, and extending to all 3-phase (or otherwise defined consumers) by 2017.
6. Policies for energy efficiency in public infrastructure including EV charging facilities by 2015 and for demand response ready appliances by 2017. Relevant policies in this regard to be finalized by 2014.
7. Development of Skill Development Centers for smart grid development in line with the National Skill Development Policy 2009 for Power Sector by 2015.

D) Other Initiatives

1. Tariff mechanisms, new energy products, energy options and programs to encourage participation of customers in the energy markets that make them “prosumers” – producers and consumers – by 2017.
2. Create an effective information exchange platform that can be shared by all market participants, including prosumers, in real time which will lead to the development of energy markets.

SMART GRID ARCHITECTURE

The European Technology Platform defines the Smart Grid as:

“A Smart Grid is an electricity network that can intelligently integrate the actions of all users connected to it – generators, consumers and those that do both – in order to efficiently deliver sustainable, economic and secure electricity supplies.”

According to the US Department of Energy :

“A smart grid uses digital technology to improve reliability, security, and efficiency (both economic and energy) of the electric system from large generation, through the delivery systems to electricity consumers and a growing number of distributed-generation and storage resources.”

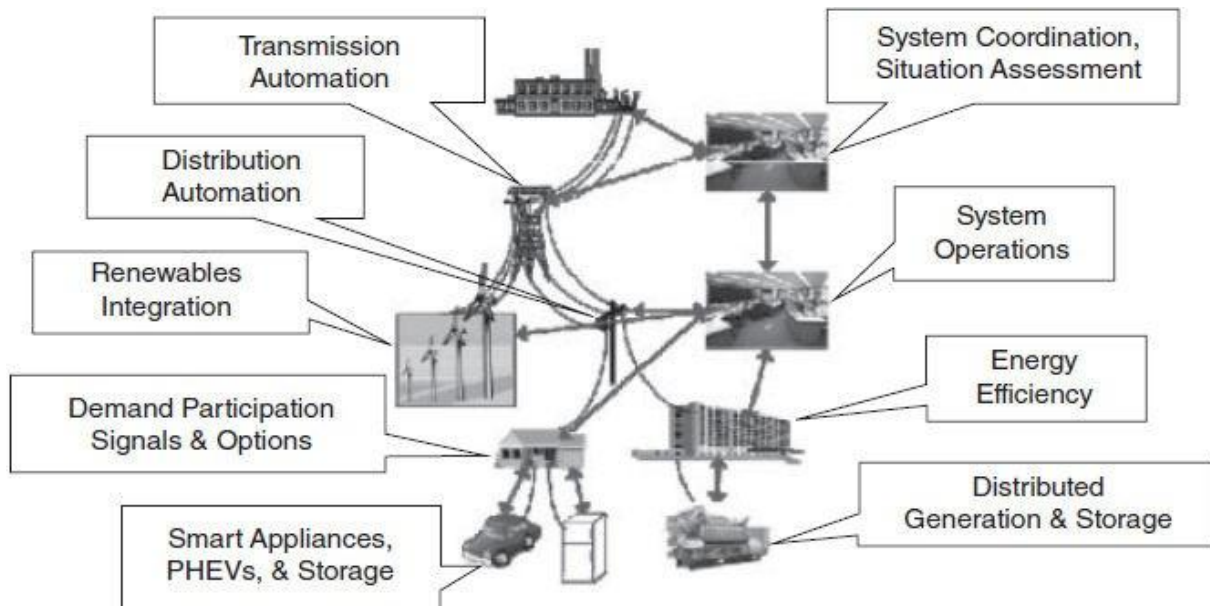

Figure 1.5. DOE Representative Architecture of the Smart Grid design (Architecture 1).

Several types of architecture have been proposed by the various bodies involved in smart grid development. We present two: one from the DOE and one illustrated by Figure 1.5 , which shows how the DOE ’ s proposed smart grid divides into nine areas: transmission automation, system coordination situation assessment, system operations, distribution automation, renewable integration, energy efficiency, distributed generation and storage, demand participation signals and options, and smart appliances, PHEVs, and storage. Figure 1.6 shows how the second architectural framework is partitioned into subsystems with layers of intelligence and technology and new tools and innovations. It involves bulk power generation, transmission, distribution, and end user level of the electric power system. The function of each component is explained in the next section.

FUNCTIONS OF SMART GRID COMPONENTS

For the generation level of the power system, smart enhancements will extend from the technologies used to improve the stability and reliability of the generation to intelligent controls and the generation mix consisting of renewable resources.

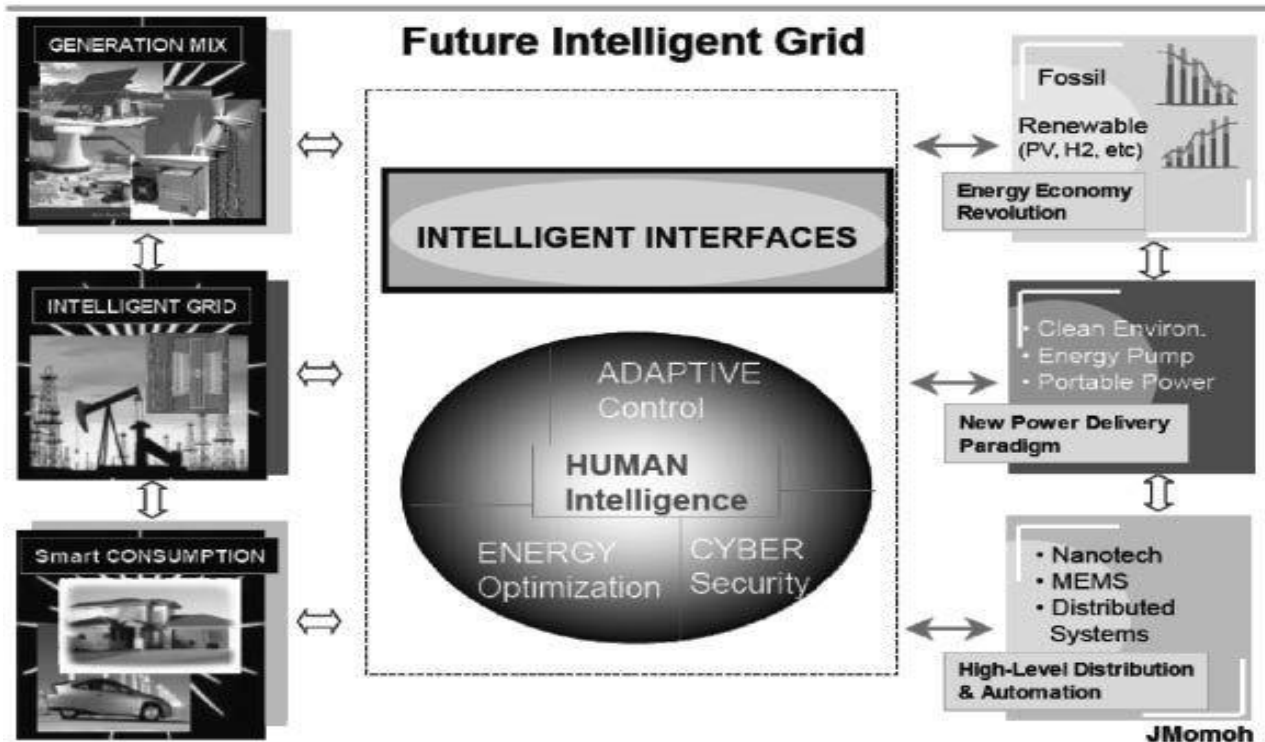

Fig :1.6 The intelligent grid (architecture 2).

1 Smart Devices Interface Component

Smart devices for monitoring and control form part of the generation components ' real time information processes. These resources need to be seamlessly integrated in the operation of both centrally distributed and district energy systems.

2 Storage Component

Due to the variability of renewable energy and the disjoint between peak availability and peak consumption, it is important to find ways to store the generated energy for later use. Options for energy storage technologies include pumped hydro, advance batteries, flow batteries, compressed air, super - conducting magnetic energy storage, super - capacitors, and flywheels. Associated market mechanisms for handling renewable energy resources, distributed generation, environmental impact and pollution are other components necessary at the generation level.

3 Transmission Subsystem Component

The transmission system that interconnects all major substation and load centers is the backbone of an integrated power system. Efficiency and reliability at an affordable cost continue to be the ultimate aims of transmission planners and operators. Transmission lines must tolerate dynamic changes in load and contingency without service disruptions. To ensure performance, reliability and quality of supply standards are preferred following contingency. Strategies to achieve smart grid performance at the transmission level include the design of analytical tools and advanced technology with intelligence for performance analysis such as dynamic optimal power flow, robust state estimation, real - time stability assessment, and reliability and market simulation tools. Real – time monitoring based on PMU, state estimators sensors, and communication technologies are the transmission subsystem ' s intelligent enabling tools for developing smart transmission functionality.

4 Monitoring and Control Technology Component

Intelligent transmission systems/assets include a smart intelligent network, self - monitoring and self - healing, and the adaptability and predictability of generation and demand robust enough to handle congestion, instability, and reliability issues. This new resilient grid has to withstand shock (durability and reliability), and be reliable to provide real - time changes in its use.

5 Intelligent Grid Distribution Subsystem Component

The distribution system is the final stage in the transmission of power to end users. Primary feeders at this voltage level supply small industrial customers and secondary distribution feeders supply residential and commercial customers. At the distribution level, intelligent support schemes will have monitoring capabilities for automation using smart meters, communication links between consumers and utility control, energy management components, and AMI.

6 Demand Side Management Component

Demand side management options and energy efficiency options developed for effective means of modifying the consumer demand to cut operating expenses from expensive generators and defer capacity addition.

DSM options provide reduced emissions in fuel production, lower costs, and contribute to reliability of generation. These options have an overall impact on the utility load curve. A standard protocol for customer delivery with two - way information highway technologies as the enabler is needed. Plug - and - play, smart energy buildings and smart homes, demand - side meters, clean air requirements, and customer interfaces for better energy efficiency will be in place.

UNIT II: WIDE AREA MONITORING SYSTEM

Fundamentals of Synchro phasor Technology – concept and benefits of wide area monitoring system–Structure and functions of Phasor Measuring Unit (PMU) and Phasor Data Concentrator (PDC)–Road Map for synchro phasor applications (NAPSI)–Operational experience and Blackout analysis using PMU

Fundamentals of Synchro phasor Technology

The Evolution of “Synchrophasor” Standard

A short account of the development of this standard may be of interest. The “Synchrophasor” standard was first issued in 1995. PMUs of early manufacture based on this standard were tested for interoperability, and it was discovered that their performance at off-nominal frequencies was not identical. From the point of interoperability of equipment, this was not acceptable. It was soon recognized that the then existing standard was not very clear on the topic of performance requirements for PMUs at off-nominal frequencies.

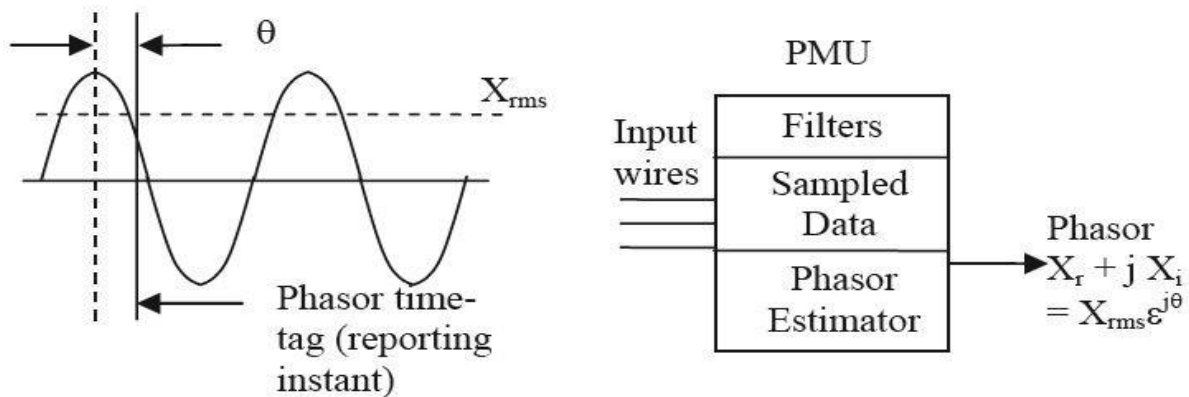

Fig.2.1 PMU performance requirements for input signals of any frequency. (a) Input signal connected to the PMU terminals, and (b) the required output phasor estimate.

A working group of the Power System Relaying Committee of IEEE undertook the revision of the standard, and the result is the current standard which clarified the requirements for PMU response to off-nominal frequency inputs. The requirements for off nominal frequencies can be explained with the help of Figure 2.1. The definition of a phasor is independent of its frequency; thus, if the input signals connected to the PMU are pure sinusoids of any frequency and the phasor estimate is reported at the time-tag as shown in Figure , the output phasor must have a magnitude equal to the rms value of the signal, and its phase angle

must be θ , the angle between the reporting instant and the peak of the sinusoid. Note that the PMUs in general contain a number of filters at the input stage. The phase delays caused by these filters must be compensated for before the phasor estimate is reported. Also, whether the input is balanced or unbalanced, the positive sequence provided by the PMU must be correct at all frequencies.

As a practical matter, the PMU Standard calls for this specification to hold over a frequency deviation of ± 5 Hz from the nominal frequency. Other new features of the standard specify the measurement accuracy requirements for two classes of PMUs, and a standardized reporting time for phasors which is phase-locked to the GPS 1 pps, and is at intervals which are multiples of nominal power frequency periods. It is also important to note that the standard does not specify the requirements for response of PMUs to power system transients.

File structure of ‘Synchrophasor’ standard

The file structure for “Synchrophasors” is similar to that of COMTRADE , which defines files for transient data collection and dissemination. COMTRADE standard has been adapted by International Electrotechnical Commission (IEC), and is now the principal international file format standard being used by computer relays, digital fault recorders, and other producers and users of power system transient data.

Synchrophasor standard defines four file types for data transmission to and from PMUs. Three files are generated by PMUs: Header files, Configuration files, and Data files. One file, the “Command File”, is for communicating with the PMUs from a higher level of the hierarchy – such as a PDC. All files have a common structure as shown in Figure2.2 . The first word of 2 bytes is for synchronization of the data transfer. The second word defines the size of the total record, the third word identifies the data originator uniquely, and the next two words provide the “second of century” (SOC) and the “fraction of a second” (FRACSEC) at which the data is being reported. The length of the Data words which follow FRACSEC depends upon the specifications provided in the Configuration file. The last word is the check sum to help determine any errors in data transmission.

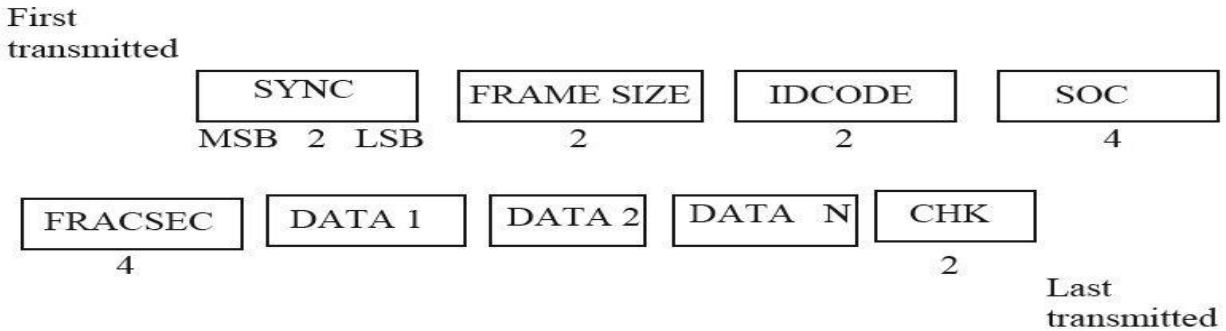

Fig 2.2 File structure of 'Synchrophasor' standard

The Header file is a human readable file, with pertinent information which the producer of data may wish to share with the user of the data. The Configuration and Data files are machine readable files with fixed formats. Configuration file provides information about the interpretation of the data contained in the data files. In practice the Header and Configuration files are sent by the PMU when the nature of the data being transferred is defined for the first time. The data files contain phasor data (and certain other related measurements such as frequency and rate of change of frequency) which is the principal output of the PMUs. Phasor data may be communicated in rectangular or polar form. Command files are used by higher levels of the hierarchy for controlling the performance of the PMUs. Several commands have been defined and are available at this time, with a number of reserved codes for commands which may be needed in the future.

PRINCIPAL APPLICATIONS AND BENEFITS OF SYNCHROPHASOR TECHNOLOGY

1.Situational awareness and wide-area monitoring:

The network of PMUs enable grid operators to see the bulk power system across an entire interconnection, understand grid conditions in real time, and diagnose and react to emerging problems. Analysts believe that synchrophasor-enabled visibility could have prevented the 2003 Northeast and the 1996 Western blackouts. As synchrophasor data quality improves, those data are being integrated into some existing control room visualization tools based on EMS and SCADA data, gaining acceptance for synchrophasor-enhanced wide-area monitoring.

2.Real-time operations:

Synchrophasor data is being used to improve state estimator models for better understanding of real-time grid conditions. It is being used to detect and address grid oscillations and voltage instability, and integrated with SCADA and EMS data to drive real-time alarms and

alerts. Analysts are looking at PMU data to expedite resolution of operating events such as fault location, and quickly diagnose equipment problems such as failing instrument transformers and system imbalances.

More advanced applications use PMU data as an input to Special Protection Systems (SPS) or Remedial Action Schemes (RAS), and can trigger automated equipment controls. PMU data can be used to monitor and manage system islanding and black-start restoration. ERCOT is using PMUs to verify customers' performance in demand response events.

3. Power system planning:

Good dynamic models allow a better understanding of how power systems respond to grid disturbances; better prediction enables better system planning with better grid and financial asset utilization. Synchrophasor data are particularly useful for validating and calibrating models of power plants, FACTS devices and other grid equipment, letting generators and grid operators comply with NERC Modeling standards with better results at lower cost. These data are also being used to improve system models, calibrating state estimators and dynamic system models and simulations. The Western Interconnection of North America has been a leader in using synchrophasor data for planning applications.

4. Forensic event analysis:

Phasor data is invaluable for post-event analysis of disturbances and blackouts. Because synchrophasor data is time-stamped, it can be used to quickly determine the sequence of events in a grid disturbance, and facilitate better model analysis and reconstruction of the disturbance. These enable a faster and deeper understanding of the disturbance causes and inform development of ways to avert such events in the future.

WIDE AREA SYNCHROPHASOR MEASUREMENT (OR) MONITORING SYSTEM

Figure 2.3 shows a typical wide area phasor measurement system. Normally the PMUs are installed at the substations across the power grid where it's relatively easy for installation and maintenance. For wide area measurement system, PMUs measure voltage and current phasors and send them to a phasor data concentrator where the time stamped voltage and current data are processed. As the core component of the measurement system, the PDC collects data from a number of PMUs or other PDCs (A super PDC). The PDC correlates phasor data by its time-tag and sample number resulting in a wide area measurement set synchronized in time.

Other functions of the PDCs include performing quality checks on the data and inserting appropriate flags to indicate data quality as well as buffering the data stream internally and spooling it out to other utility applications.

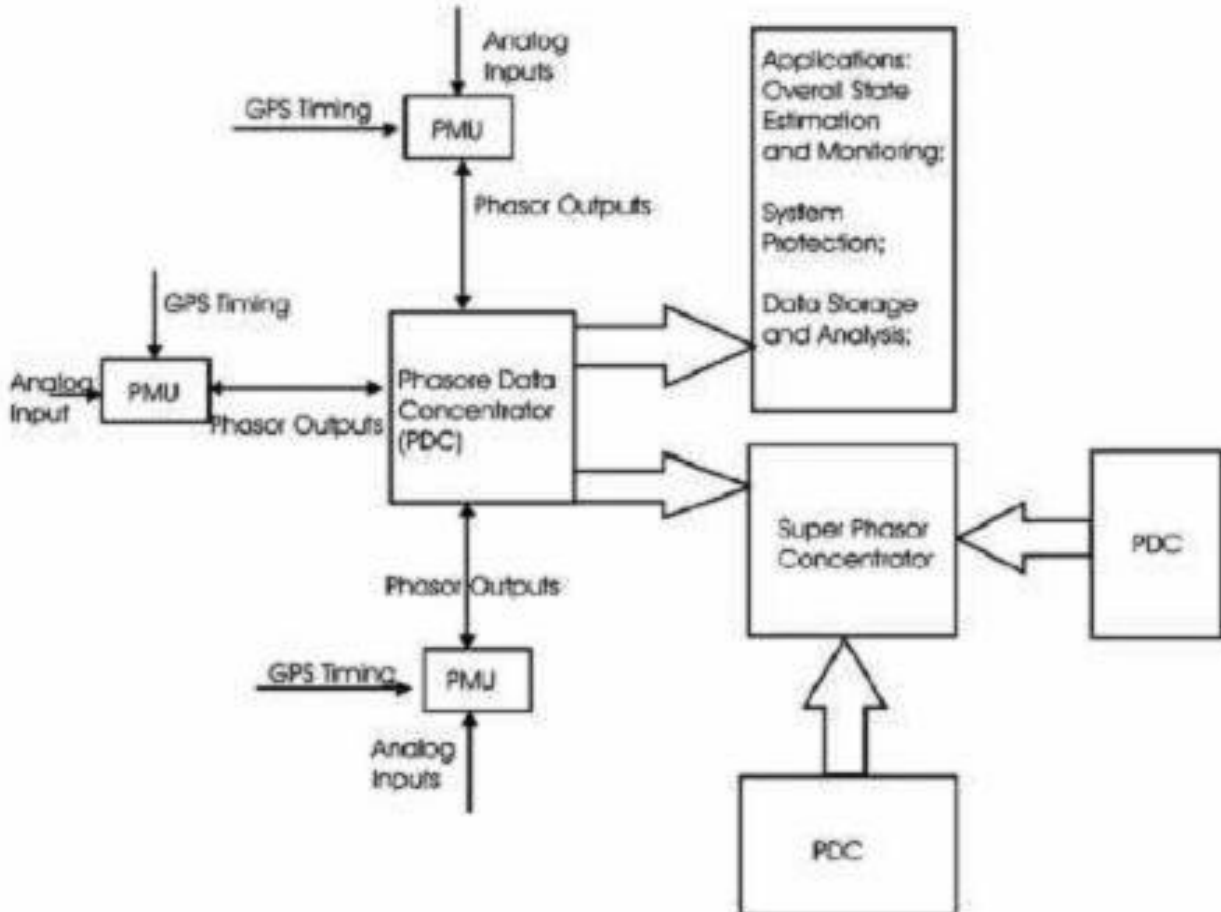

Figure 2.3 Wide area phasor measurement system

The parsed phasor signals from the PDCs are then used to monitor and protect the electrical power system. The state of the art technology to make estimation is based on unsynchronized measurements to solve a nonlinear equation. The real-time synchrophasor data make the dynamic system state estimation reasonable and realistic. The real time synchrophasor data helps to protect the power system. With such data, if one part of the power grid is out of synch with the others to certain extent, the operator can shut down that part only to prevent the whole grid being shut down or becoming unstable.

The synchrophasor data also helps the power system engineers do post event analysis. Without the synchrophasor data, due to the fact that the data recorded before a big black out lack time stamp it is extremely difficult to do the analysis, if not impossible since there is no efficient way to tell which event comes first to trigger the other event.

The measurement technique for voltage and current phasors was first proposed as a part of Symmetrical Component Distance Relay. Later it became apparent that it would be profitable to use phasor information in numerous protection and control applications, so the special unit was designed.

BENEFITS OF WAMS

Following are some of the benefits of synchrophasors technology:

(i) The Operators are additionally provided with online information at the right time for improved power system operation.

(ii) With real time information on angular separation between the buses and its voltages, transmission load ability in lines may be increased considerably, Therefore more power can be transmitted on existing lines and construction of new lines can be deferred and also resulting in better utilization of the existing transmission system/assets.

(iii) Early detection of critical conditions in the grid and accordingly taking corrective operational measures to avert grid disturbance.

(iv) Detection of power system oscillation by Synchrophasor technology would enable tuning of PSS/ voltage stabilizer and thereby healthy operation of the machines for a longer period.

(v) Improved knowledge of the power system conditions and corrective actions prevents excessive or unnecessary load shedding.

(vi) The relay operation characteristic can be validated in real time.

(vii) According to the behaviour of the real time system dynamics measured & monitored by the technology, Defence Plan/ Islanding scheme(s) can be designed to avert grid collapse.

(viii) The technology will provide more intelligence on network security and help to improve and maintain the robustness of the grid.

(ix) Objectives of secure, safe, reliable and smart grid operation will be achievable through WAMs technology.

PHASE MEASUREMENT UNIT

Historically, the first Phasor Measurement Unit was built for American Electric Power (AEP) and the Bonneville Power Administration (BPA). The first commercial PMU, called Macrodyne 1690 was introduced in 1991. The original IEEE Standard 1344 for Synchrophasor for Power was completed in 1995 and revised in 2005. The new standard, IEEE Standard C37.118-2005, provides details of the basic measurement requirements and verification. Figure 2.4 is a block diagram for a general purpose Phasor Measurement Unit. A GPS receiver obtains timing signals from GPS satellites to generate the system clock for A/D converter and PMU microprocessor. Voltage and current signals coming from PTs or CTs are sampled by the A/D converter with reference to GPS clock. The digital voltage and current signals are fed to the microprocessor synchronous with GPS clock.

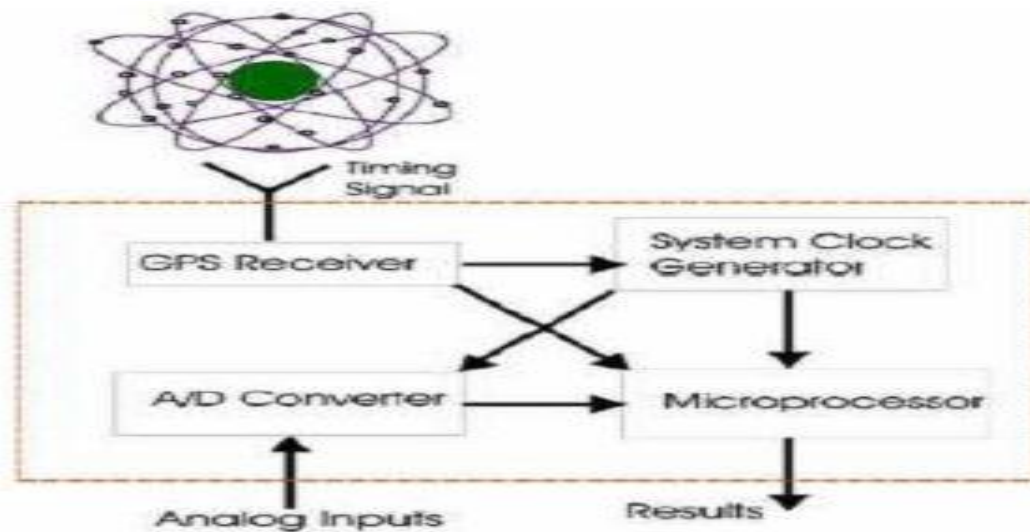

Fig 2.4 General purpose Phasor Measurement Unit

The IEEE standard states that the phasor measurement should be synchronized to UTC time with accuracy high enough accuracy to meet the accuracy requirements. The timing signal error is in the range of $1 \mu\text{s}$ from GPS which corresponds to an angular accuracy of 0.022 (360 degree/16600) degree for a 60 Hz system or 0.018 (360 degree/20000) degree for a 50 Hz system. Since the phases are calculated relative to a nominal system frequency (50/60Hz), the phase angle will change constantly for an off nominal frequency. As a result, a 0.1 Hz deviation for a 50 Hz system will lead to 1 cycle forward per 10 seconds. In the real world, the measured phase angle will usually be rotating one way or the other depending on the difference between the set nominal frequency and the actual system frequency. For most

applications, the angle difference among “hot” spots is more critical. Different data transmitting rates complicate the whole process to make measurements and comparison.

The analog inputs are currents and voltages obtained from the secondary windings of the current and voltage transformers. All three phase currents and voltages are used so that positive-sequence measurement can be carried out. In contrast to a relay, a PMU may have currents in several feeders originating in the substation and voltages belonging to various buses in the substation.

The current and voltage signals are converted to voltages with appropriate shunts or instrument transformers (typically within the range of ± 10 volts) so that they are matched with the requirements of the analog-to digital converters. The sampling rate chosen for the sampling process dictates the frequency response of the anti-aliasing filters. In most cases these are analog-type filters with a cut-off frequency less than half the sampling frequency in order to satisfy the Nyquist criterion. As in many relay designs one may use a high sampling rate (called oversampling) with corresponding high cut-off frequency of the analog anti-aliasing filters. This step is then followed by a digital ‘decimation filter’ which converts the sampled data to a lower sampling rate, thus providing a ‘digital anti-aliasing filter’ concatenated with the analog anti-aliasing filters.

The advantage of such a scheme is that the effective anti-aliasing filters made up of an analog front end and a digital decimation filter are far more stable as far as aging and temperature variations are concerned. This ensures that all the analog signals have the same phase shift and attenuation, thus assuring that the phase angle differences and relative magnitudes of the different signals are unchanged.

As an added benefit of the oversampling technique, if there is a possibility of storing raw data from samples of the analog signals, they can be of great utility as high-bandwidth “digital fault recorders”.

The sampling clock is phase-locked with the GPS clock pulse (to be described in the following section). Sampling rates have been going up steadily over the years – starting with a rate of 12 samples per cycle of the nominal power frequency in the first PMUs to as high as 96 or 128 samples per cycle in more modern devices, as faster analog-to-digital converters and

microprocessors have become commonplace. Even higher sampling rates are certainly likely in the future leading to more accurate phasor estimates, since higher sampling rates do lead to improved estimation accuracy.

DESIGN AND OPERATION

Figure 2.5 shows the basic and generic block diagram of the PMU instrument. It consists of input signal conditioning circuits that interfaces with the voltage transformers (VT) and current transformers (CT), analogue to digital converters that interface with a host processor, a master (synchronised) timing generator and a communications interface. Below we describe each part in more detail.

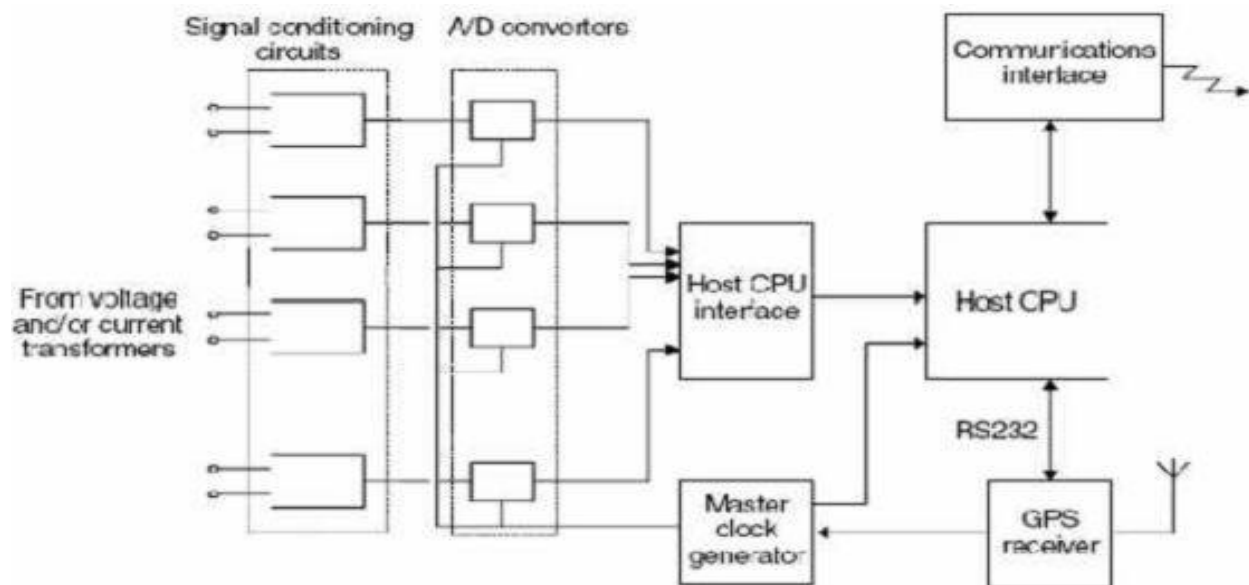

Fig2.5.Basic and Generic Block Diagram of the PMU

1. Signal conditioning circuit and A/D converter

The signal conditioning circuit interfaces directly to the VT (or CT). It performs current to voltage conversion if necessary, prevents overloading and protects the rest of the circuit and does the required filtering at the Nyquist rate. It is very important that the 'live' section of the whole system should be isolated from the rest. This poses quite a problem in terms of circuit design, especially if one wants high-quality samples. The simplest approach is to use an input isolation transformer, followed by an amplifier/filter and A/D converter. Although this is a very cheap solution, problems such as poor common mode rejection, phase variation and drift,

soon arises. Furthermore, it cannot measure DC quantities such as offset currents and transducer outputs.

The modern approach is to make use of a high-quality active instrumentation amplifier followed directly by the A/D converter. Isolation is achieved by optical coupling of the A/D outputs and control signals. Power is supplied to the 'live' circuit by means of an isolated switch mode power supply (SMPS). This is shown in Fig. 2.5 The design can be further improved by making use of an A/D converter with built-in anti-aliasing filtering. Such devices are commonplace these days and are referred to as 'codecs'. These devices usually employ 1-bit delta-sigma A/D converters, digital filtering and sample decimation, all in one package.

A further advantage is that the A/D output is available in serial form (clock/data), which simplifies the optical isolation design, although it does usually require a more complex host processor interface. This design achieves a minimum common mode rejection ratio of roughly 90 dB across the operating spectrum and an A/D converter dynamic range in excess of 80 dB

2. Host interface

The host interface connects the front-end and A/D converter to the host controller. It is important that this is done in such a way as to minimize the overhead when data is transferred to and from the controller. The host controller will not generate the master sampling clock, and the minimum transfer requirement would be some form of interrupt driven process. These interrupts should be kept to a minimum, and data should be transferred in bursts of maximum length while still maintaining the desired phasor output rate.

3. Master clock generator and GPS receiver

It is vital that all the PMU's across the power network operates synchronously. Such a synchronous system requires that the individual sampling clocks are frequency and phase locked. Fortunately there are a number of Global Positioning System satellites in orbit, which not only provides the position of a receiver within a 10 m space, but also a common-view time transmission. With an appropriate GPS receiver it is possible to obtain a 1 pulse per second (1 PPS) signals with an accuracy of 1 ms anywhere in the world. These receivers also provide an absolute time-tag, which, in conjunction with the 1 PPS signal, can provide a phasor

measurement with a unique time-stamp. These time-stamped measurements can then be collected and processed at a central point.

4. Communications interface

The resultant time tagged phasors are immediately available for local and/or remote applications via the standard RS232 serial communications ports. An Ethernet adapter is not available yet as a part of PMU hardware. It will give much higher rates and make networking task easier.

5. Host controller

The host controller plays a central role in the whole PMU instrument. It collects and processes data, issues the control signals and communicates with other units as well as a central location. Data acquisition and phasor calculation was mentioned that the host processor should be able to communicate with the A/D interface efficiently and with as little overhead as possible. Assuming that this has been accomplished, the host controller can store the channel samples in an onboard buffer. For the phasor calculations, only the most recent sample is needed. However, for the purposes of event recording, a longer record will be needed. This can be accomplished by storing the most recent samples in a circular buffer. All calculations, triggering and other events can then make use of this data. Further functionality may also include the use of mass storage devices such as hard-disks and tapes.

The most important function of the host processor is to calculate voltage and current phasors in real-time. The phasor calculation is based on a recursive Discrete Fourier Transform (DFT) algorithm. The phasor is stationary for a 50 Hz frequency. If the fundamental frequency deviates from 50 Hz, the phasor will rotate with an angular velocity equal to the frequency deviation. It should be emphasized that algorithm will filter out all harmonics which are multiples of the 50 Hz fundamental. A three phase version of this algorithm is directly derived using symmetrical component theory. The samples from all three phases are used and the positive sequence fundamental frequency phasor is estimated. The algorithm is capable of estimating a positive sequence phasor from unbalanced three-phase signals.

SOME OF THE PMU VENDORS

1. AREVA T&D - P847 Phasor Measurement Unit
2. ABB - RES 521
3. GEMultilin – D60, L90
4. Siemens - SIMEAS R-PMU
5. SEL - SEL-421 and SEL-451

APPLICATIONS OF PMU

Information about dynamic behavior of power system can be extracted from raw data obtained from field through PMU. This can be achieved by using computer aided tools that process the raw data and extract usable information from it for intelligent system operation control and planning. Historically these functions are provided by computer aided tools called energy management systems, state estimation, load flow, load forecast and economic dispatch. After introducing phasor measurement units to the power systems phasor data can be used to develop conventional applications and may facilitate development of new analytics/application due to availability of system information at 25 or 50 samples per sec.

Some of these applications being developed are:

- i. Low frequency oscillation monitoring
- ii. Line Parameter Estimation
- iii. Online Vulnerability Analysis of Distance Relays
- iv. Linear/Dynamic State Estimator
- v. CT/CVT calibration
- vi. Control Schemes for improving system security.(based on angular, voltage and frequency instability)

A. Low frequency oscillation monitoring

Long distance bulk transfer of power may lead to low frequency oscillations. Effective monitoring and analyses are required to control low frequency oscillation. Wide area measurement systems measure all the physical variables of power systems at sub-seconds frequency. This sub-sec. data can be used to compute oscillation frequency using signal analysis technique to determine modes present in the frequency signal along with amplitude and damping ration to analyse the dynamic behaviour of power system.

B. Line Parameter Estimation

Availability of time synchronized data across wide area network has facilitated line parameter data estimation i.e. resistance, reactance and susceptance. Phasor measurement gives an opportunity to calculate positive sequence and zero sequence directly from the measurements. Least square and total least square techniques can be used to estimate line data using phasor measurements.

C. Online Vulnerability Analysis of Distance Relays

Relays in transmission lines are used to isolate line during fault conditions. However due to changing network conditions and over a period of time they become vulnerable to false tripping. WAMs data will enable the tracking of relay characteristic. The apparent impedance trajectory through online PMU data is superimposed on relay characteristic to identify the vulnerability of distance relays to tripping on Power Swing and Load Encroachment so that corrective measures can be taken accordingly.

D. Linear/Dynamic State Estimator

Traditionally, a state estimator uses asynchronous measurements of real and reactive power flows and voltage magnitudes. This makes the state estimator nonlinear and hence iterative techniques are required. With PMUs in place, it is possible to synchronously measure voltage and current phasors. As a result, state estimation becomes a linear problem and hence can be solved in a single step. The application will help in determination of bad data, topological error, island in the network, inconsistencies in model, alarms for limit violations and early warnings.

E. CT/CVT Calibration

Instrument transformers, especially CVTs, suffer from drift in characteristics under different operating conditions and over a period of time. The accuracy of these instruments can be evaluated using highly accurate synchrophasor measurement. Bench mark CVT in network can act as reference for calculating other CVT in the network or residual error of State Estimation over a long period of time can be used to identify these errors.

F. Control Schemes for improving system security

Control schemes are fast and high impact schemes to ensure system integrity, or at least minimize the adverse effects of a disturbance. Global signals provided by synchrophasors allow

for more reliable decision making. Controls, involve automatic actions taken in relatively short time (2-3 Sec) where direct operator intervention may not be feasible.

Trajectories of various parameter line voltage, current and status information of Circuit Breaker (CB) can be continuously monitored and analysed for stability and detect events which may harm the system stability.

Based on the analysis of the evolving trajectories a decision on whether to take an automatic control action and its quantum & location can to be taken by such a scheme.

PHASOR DATA CONCENTRATOR UNIT (PDC)

The PDC and the super PDC (SPDC) of Figure are important elements of the overall PMU system organization. Their principal functions are to collate data from different PMUs with identical time-tags, to create archival files of data for future retrieval and use, and to make data stream available to application tasks with appropriate speed and latency. As yet are no industry standards for the PDC data files. However, it is generally understood that PDCs will have file structures similar to those of PMUs. There are no commercially available PDCs at this time. Most existing PDCs have been custom built by researchers or manufacturers of PMUs. As wider implementation of PMU technology takes place, the industry will no doubt work toward creating standards for these important components of the overall PMU infrastructure.

The PMUs are installed in power system substations. The selection of substations where these installations take place depends upon the use to be made of the measurements they provide. The optimal placement of PMUs will be considered in some of the following chapters which discuss some of the applications of phasor measurements. In most applications, the phasor data is used at locations remote from the PMUs. Thus an architecture involving PMUs, communication links, and data concentrators must exist in order to realize the full benefit of the PMU measurement system. A generally accepted architecture of such a system is shown in Figure 2.6.

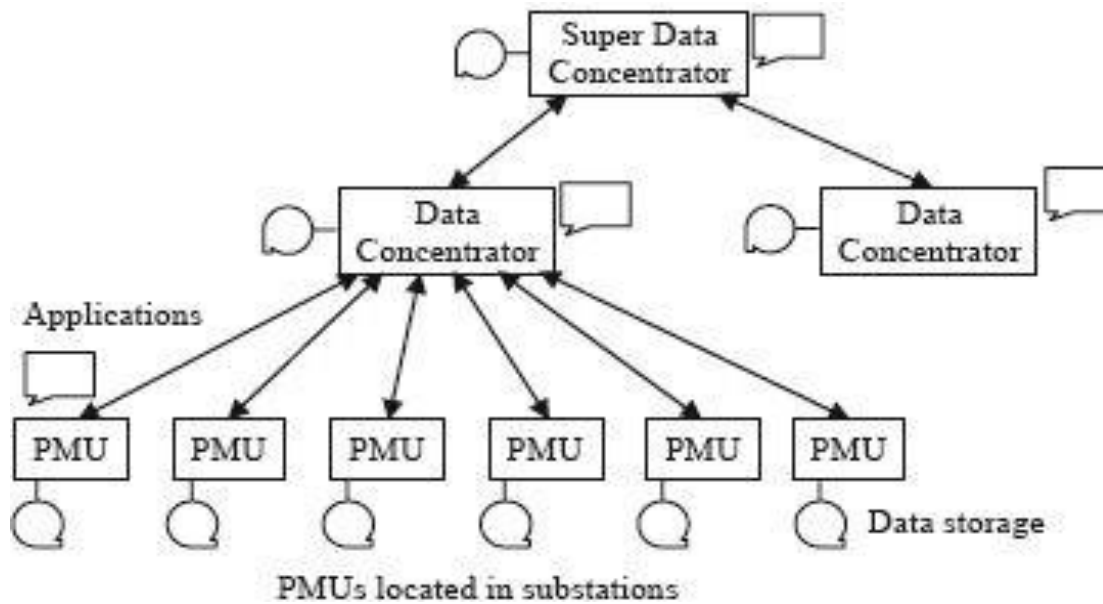

Fig 2.6 Phasor Data Concentrator

In Figure 2.6 the PMUs are situated in power system substations, and provide measurements of time-stamped positive-sequence voltages and currents of all monitored buses and feeders (as well as frequency and rate of change of frequency). The measurements are stored in local data storage devices, which can be accessed from remote locations for post-mortem or diagnostic purposes. The local storage capacity is necessarily limited, and the stored data belonging to an interesting power system event must be flagged for permanent storage so that it is not overwritten when the local storage capacity is exhausted. The phasor data is also available for realtime applications in a steady stream as soon as the measurements are made. There may well be some local application tasks which require PMU data, in which case it can be made available locally for such tasks. However, the main use of the real-time data is at a higher level where data from several PMUs is available.

The devices at next level of the hierarchy are commonly known as “phasor data concentrators” (PDCs). Typical function of the PDCs is to gather data from several PMUs, reject bad data, align the time-stamps, and create a coherent record of simultaneously recorded data from a wider part of the power system. There are local storage facilities in the PDCs, as well as application functions which need the PMU data available at the PDC. This can be made available by the PDCs to the local applications in real time. (Clearly, the communication and data management delays at the PDCs will create greater latency in the real-time data, but all practical

experience shows that this is not unmanageable. The question of data latency will be further considered when applications are discussed in later chapters.)

One may view the first hierarchical level of PDCs as being regional in their data-gathering capability. On a system wide scale, one must contemplate another level of the hierarchy (Super Data Concentrator in Figure 2.6). The functions at this level are similar to those at the PDC levels – that is, there is facility for data storage of data aligned with time-tags (at a somewhat increased data latency), as well as a steady stream of near realtime data for applications which require data over the entire system.

ROAD MAP FOR SYNCHRO PHASOR APPLICATIONS (NASPI)

North American SynchroPhasor Initiative

NASPI brings together the utility industry, manufacturers and vendors, academia, national laboratories, government experts and standards-making bodies. This large volunteer community dedicated to synchrophasor technology advancement has collaborated to address and solve technical, institutional, standards development, and other strategic issues and obstacles. NASPI works to accelerate the maturity and capabilities of synchrophasor technology, to improve the reliability and efficiency of the bulk power system. The NASPI Work Group meets twice a year, with financial support from the United States Department of Energy and the Electric Power Research Institute.

The NASPI Task Force on Testing and Certification has recommended that users of synchrophasor measurements require that the PMUs producing those measurements be certified compliant with IEEE C37.118.1. The IEEE Standards Association has developed a synchrophasor conformity assessment program for testing PMU compliance with respect to the IEEE standard.

NASPI's doing to accelerate Synchrophasor Technology maturity

- Sharing users' and vendors' success stories and high-value applications
- Accelerating development of technical interoperability standards
- Focusing and facilitating baselining and pattern recognition research (e.g., oscillation detection) and other R&D
- Early identification of project implementation challenges and community work to develop and share solutions

- Develop and test PMU device specifications and interoperability
- Communications network design
- PMU placement
- End-to-end data flow and quality
- Developing requirements for “production-grade” systems
- Building key software infrastructure (NERC GPA investment)
- Enhance applications value and operator and user training
- On the horizon – more technical standards; cyber-security and GPS

Target Timing of Phasor Applications and Prerequisites

2012

- Majority of new PMUs installed or updated
- Wide-area visualization applications, voltage and frequency monitoring in use
- Many phasor-related technical standards complete

2013

- All SGIG PMUs installed and networked
- Phasor data starts feeding state estimators
- All communications networks and associated data management infrastructure complete

and in testing

- Model validation and system studies under way
- Baseline and pattern recognition analysis under way

2014

- Communications networks become production-grade
- Situational awareness applications production-grade
- Renewables integration using voltage and frequency stability monitoring, oscillation

monitoring

- Designing system operating limits for alarming
- Early operator support tools in pilot

2015 and later

- Working on automated controls and controlled separation
- Dynamic state estimation

Percent Completed

Box Colors:
(reflect the value of phasor measurements for the tasks)

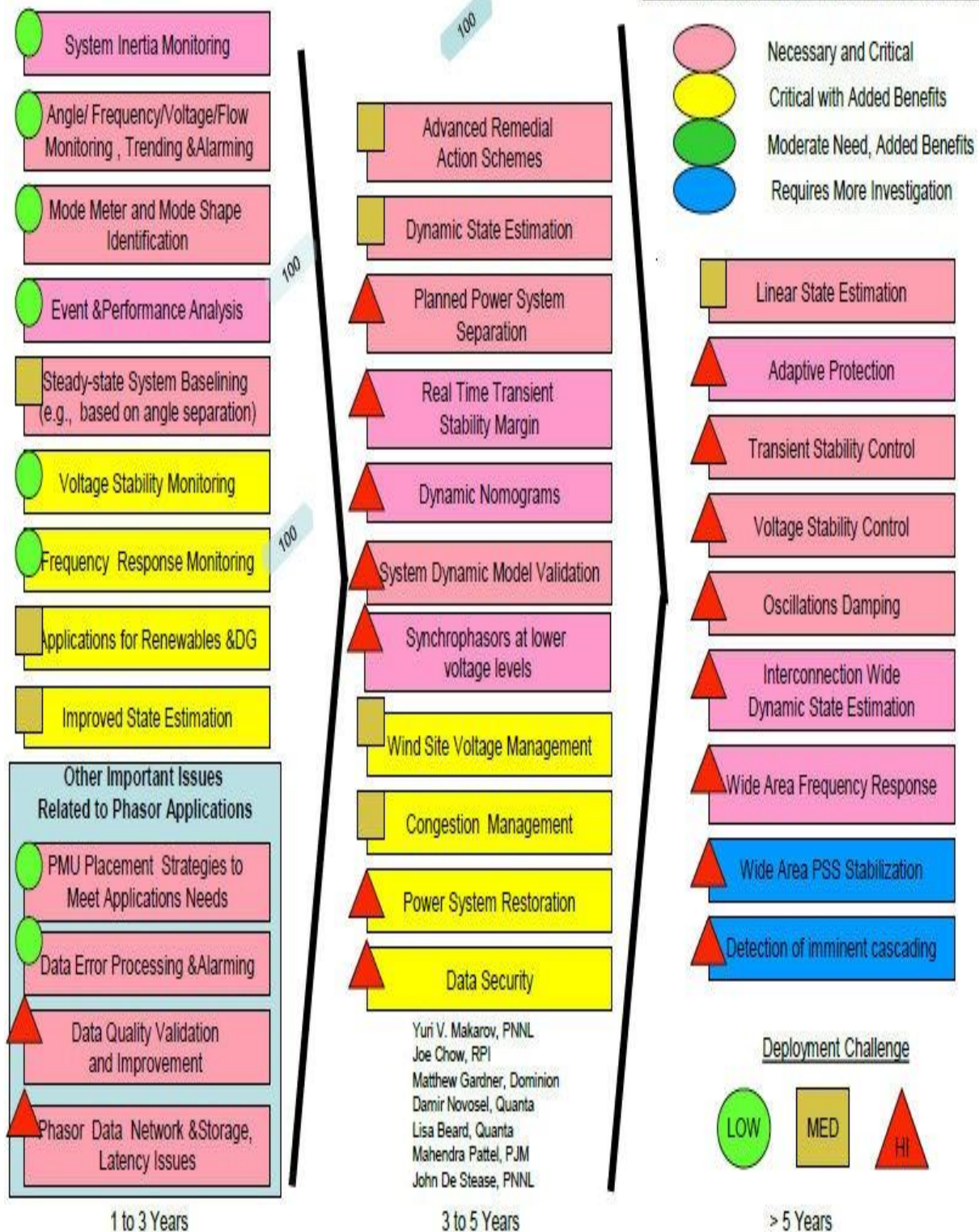

UNIT III: SMART METERS

Features and functions of smart meters– Functional specification–category of smart meters– AMR and AMI drivers and benefits– AMI protocol– Demand Side Integration–Peak load, Outage and Power Quality management

OVERVIEW OF SMART ELECTRICITY METERS

Smart meters are considered to be the backbone of Smart Grid deployment — the first move into two-way communication between power providers and their customers. Smart meters provide better real-time information to utilities about the quality of power supply and the customer demand for electricity and gas at any given moment. Based on actual deployments of smart meters globally, those benefits translate into more reliable service, streamlined billing, and reduced power loss. For consumers, use of smart meters makes understanding their consumption information easier, can help them better manage their costs, and removes the inconveniences associated with switching suppliers. More importantly, smart meters promote energy conservation. Finally, if meters for electricity, gas, and water leverage common communications methods, there can be significant benefits to each of the serving utilities by providing a platform that supports the metering requirements along with other critical monitoring functions. However, those benefits will hinge upon the reliability, interoperability, life span and ultimately the long-term cost savings of the meters and the associated communication infrastructure.

Smart metering essentially involves an electronic power meter supplemented by full remote control, diagnostics, power peak and consumption analysis, anti-tampering mechanisms, fault alert, time-variable tariffs, and many more possibilities.

Smart meters are electronic measurement devices used by utilities to communicate information for billing customers and operating their electric systems. For over fifteen years electronic meters, have been used effectively by utilities in delivering accurate billing data for at least a portion of their customer base. Initially, the use of this technology was applied to commercial and industrial customers due to the need for more sophisticated rates and more granular billing data requirements. The use of electronic meters came into service to the largest customers of the utility and over time gradually expanded to all customer classes. This migration was made possible by decreasing cost of the technology and advanced billing requirements for all customer classes.

Using Power-Line Communication (PLC) or other wired and wireless technologies to

connect the meter to the service provider enables all of the above features to be feasible and compatible with future smart-grid protocols.

Although the smart, meters are relatively new to the utility industry, they are treated with the same due diligence and scrutiny associated with electronic meters and older electromechanical counterparts. These meters have always met or exceeded national standards such as American National Standards Institute (ANSI) C12.1 for meter accuracy and design. In addition, equipment used to certify meter performance must be traceable to the National Institute of Standards and Technologies (NIST), a federal agency that works with industry to properly apply technology and measurements.

Other standards in use for the smart meter installations include National Electric Code (NEC) for home electrical wiring, National Electrical Manufacturers Association (NEMA) and Underwriters Laboratories (UL) for enclosures and devices, and National Electric Safety Code (NESC) for utility wiring. Through the leadership of utility metering professionals and metering manufacturers, the meticulous and deliberate development of these solid state electronic measurement devices has resulted in meter products that have advanced functionality, are stable and have tighter accuracy tolerances, and are more cost effective for advanced features than the legacy electromechanical technologies.

Purpose of Smart Meter

Since the inception of electricity deregulation and market-driven pricing throughout the world, utilities have been looking for a means to match consumption with generation. Traditional electrical and gas meters only measure total consumption, and so provide no information of when the energy was consumed at each metered site (market use rates are readily available to utilities however). Smart meters provide a way of measuring this site- specific information, allowing price setting agencies to introduce different prices for consumption based on the time of day and the season. Smart meters may include measurements of surge voltages and harmonic distortion, allowing diagnosis of power quality problems.

Utility companies propose that from a consumer perspective, smart metering offers potential benefits to householders. These include: (i) an end to estimated bills, which are a major source of complaints for many customers, (ii) a tool to help consumers better manage their energy use — stating that smart meters with a display outside their homes could provide up-to-

date information on gas and electricity consumption and in doing so help people to manage their energy use and reduce their energy bills and carbon emissions. Electricity pricing usually peaks at certain predictable times of the day and the season. In particular, if generation is constrained, prices can rise if power from other jurisdictions or more costly generation is brought online. Proponents assert that billing customers by time-of-day will encourage consumers to adjust their consumption habits to be more responsive to market prices and assert further, that regulatory and market design agencies hope these “price signals” could delay the construction of additional generation or at least the purchase of energy from higher priced sources, thereby controlling the steady and rapid increase of electricity prices. There are some concerns, however, that low income and vulnerable consumers may not benefit from intraday time of use tariffs.

Smart Meters

Smart meters are electronic measurement devices used by utilities to communicate information for billing customers and operating their electric systems. It is usually an electronic device that records consumption of electric energy in intervals of an hour or less and communicates that information at least daily back to the utility for monitoring and billing purposes. Smart meters enable two-way communication between the meter and the central system. Unlike home energy monitors, smart meters can gather data for remote reporting. Such an advanced metering infrastructure (AMI) differs from traditional automatic meter reading (AMR) in that it enables two-way communications with the meter. For over fifteen years electronic meters, have been used effectively by utilities in delivering accurate billing data for at least a portion of their customer base.

The arrival of solid state meters has meant a major breakthrough in terms of measurement technology, replacing the old system for electronic components. This has greatly improved the accuracy, reliability and size of these devices, which can also measure - without major additional costs - a greater number of variables, such as reactive power, power factor, harmonic currents and maximum power, among others. Additionally, progress in communication technologies has allowed these meters to optionally transmit data through various means, for example, PLC, RF, GSM/GPRS, etc. There is no universal definition for the term Smart Meter but it typically refers to a solid state meter with real-time communications enabled, capable of storing at least 15-min interval measurements, and additional features that are useful both for the utility and customers. These advanced meters, together with the entire communication network and data management

supporting them, forms what is it called as AMI.

Initially, the use of this technology was applied to commercial and industrial customers due to the need for more sophisticated rates and more granular billing data requirements. The use of electronic meters came into service to the largest customers of the utility and over time gradually expanded to all customer classes. This migration was made possible by decreasing cost of the technology and advanced billing requirements for all customer classes.

The combination of the electronic meters with two-way communications technology for information, monitor, and control is commonly referred to as Advanced Metering Infrastructure (AMI). Previous systems, which utilized one-way communications to collect meter data were referred to as AMR (Automated Meter Reading) Systems. AMI has developed over time, from its roots as a metering reading substitute (AMR) to today's two-way communication and data system. The evolution from AMR to AMI is shown in Fig. 3.1 with lists of stakeholders and benefactors for each step in Smart meter evolution.

Similar meters, usually referred to as interval or time-of-use meters, have existed for years, but "Smart Meters" usually involve real-time or near real-time sensors, power outage notification, and power quality monitoring. These additional features are more than simple automated meter reading (AMR). They are similar in many respects to advanced metering infrastructure meters. Interval and time of use meters historically have been installed to measure commercial and industrial customers, but may not have automatic reading.

One smart meter in isolation has limited uses. However, if the majority of meters in an area are now "smart", the utility is able to reap large benefits. With the added information provided by large numbers of smart meters, a utility can adjust their services as needed to improve the efficiency, reliability, costs, and sustainability of their services.

The figure below (Figure. 8.4) depicts the overview of a smart metering system

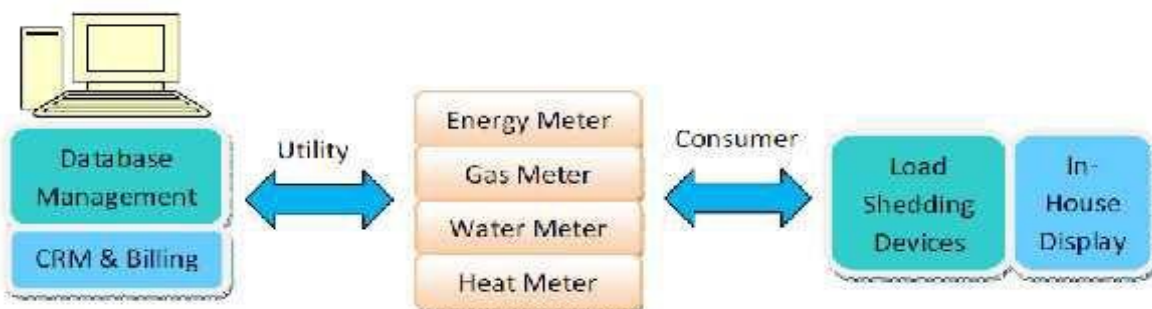

Figure 8.4: Overview of a typical smart metering system

FEATURES OF SMART METERING SYSTEM

Like conventional meters, Smart Meters measure amounts of energy or water flowing through them. But whereas conventional meters must be read manually, and the consumption calculated since the last reading, Smart Meters provide specific information on how much energy or water was consumed, when it was consumed and at what tariff – a continuous calculation that conventional meters are incapable of. Provided with detailed operational data

the network operator is also able to decrease the cost to serve, by targeting investment in the network more accurately and thus maximizing the benefits of system reinforcement. Smart Metering enables data communication and can measure and deliver more information. More quantities and larger amounts of data can be stored until collected and meters can also be reprogrammed or re-configured remotely. It also enables long range communication with the energy company and short range links into the home. Consumption data can be read remotely and tariffs can be updated remotely.

Smart Metering provides a communication gateway that functions as an interface between devices in the home and provides customers with real time data. Smart Metering allows for remote configuration and adjustment. This can be used in a number of ways, for instance, for supplier switching, remote reconfiguration of the meter as a credit or pay as you go meter, as the customer chooses to switch their supply contract. Finally, the meter can be used as the interface of a home automation network. Smart Metering can greatly assist the network operator by providing detailed operating data from the ends of the network. Power quality can be measured by the meters and the network adjusted to improve its overall operation. Outages or leakages can be detected faster and system recovery monitored, minimizing inconvenience to customers.

Using these functionalities Smart Metering can support a whole range of new services. The revolution in Smart Metering is seeing these features transferred to the residential and small commercial sectors with significant benefits to consumers, utilities, environment and society.

- 1) INFORMATION ON ENERGY CONSUMPTION**
- 2) CUSTOMER SUPPLY CONTRACTS**
- 3) RUNNING ENERGY BUSINESSES BETTER**
- 4) MULTI-UTILITIES**
- 5) RENEWABLE AND DISTRIBUTED GENERATION**

1) INFORMATION ON ENERGY CONSUMPTION

Traditionally, the primary role of utility metering has been to accurately measure usage of electricity, gas, water and heat. Until now this usage data has been – with some exceptions manually collected by the utilities. Consequently utilities lack quality data on the consumption of their customers. This limits the frequency and accuracy of consumers' bills, and the ability of utilities to engage with customers. Smart Metering will revolutionize the availability and usefulness of consumption data. It will empower consumers, raise customers' awareness of their energy and water use and allow them to make informed decisions on heating, lighting and appliance upgrades. Ultimately this will lead to a significant change in consumer behavior towards sustainable consumption patterns.

i) Better billing

Smart Metering will allow utilities to send their customers more accurate bills based on actual consumption data. Using these bills utilities can provide targeted advice on energy consumption and allow customers to see long-term trends in their consumption. Detailed consumption data helps customers understand how they use energy and empowers them to reduce their consumption.

ii) On-line data

Many utilities now provide their customers with website portals where they can view their bills. With data provided by Smart Metering technologies these can be made much richer environments where customers can benchmark their consumption and carry out analysis on energy-saving investments.

iii) Real-time feedback

The local communications interface allows data to be streamed directly to displays in the house or local software applications. This data can be provided in real time at very short intervals so that customers can immediately see the effect of turning individual appliances on and off. This will enable customers to understand in much greater detail the way they use energy and the relative impact of different appliances. The data can also be converted to currency or carbon basis to increase its relevance to the customer. Customers can also use real time feedback to set alarms that alert them to unusually high consumption. Giving customers direct feedback on their energy usage will enable them to reduce their consumption without affecting their quality of life.

2) CUSTOMER SUPPLY CONTRACTS

At the moment conventional meters only allow utilities to offer simple supply contracts to their residential customers with a maximum of one or two rates and profiled consumption patterns. Smart Meters will make it possible for utilities to offer more varied contracts. Figure 8.5 depicts the various features of a typical smart meter.

i) Demand response

Smart Meters can support a larger number of Time of Use (ToU) rates so that utilities can charge different tariffs at different times of the day, reflecting the true cost of generating the electricity. Utilities can also offer contracts that have a premium rate for occasional peaks in demand (critical peak pricing, CPP). The meter communications can be used to warn customers in advance before peak rates apply.

ii) Dynamic tariffs

Smart Metering allows for greater flexibility in supply offers. Consumers can actively react to price signals.

iii) Load management

Suppliers will be able to offer their customers a contract allowing the energy company to remotely adjust the customer's load. For example, the energy company can remotely raise the set point for an air conditioning thermostat in the customer's property. Although the customer will not notice much difference, the net reduction in the load can be enough to keep reserve capacity at safe levels or even prevent a collapse of the system and reduce costs. The energy company can, in turn, pass these savings to the customer. Trials have shown that much of this reduction is sustainable.

iv) Interval data billing

Smart Metering systems can measure and collect 'interval data' where the consumption is recorded every half hour or so. This data is currently used for large customers but is too expensive to collect with conventional residential metering. It allows the customer to be charged for the actual cost of the electricity they use instead of receiving estimated bills.

v) Energy services

Looking further forward, Smart Metering and two-way communications will give utilities the ability to use more detailed consumption data and information to deliver new and innovative energy and water services – selling energy and water-efficiency products, etc rather than

“simply” energy.

vi) Pre-payment

Electricity Smart Meters fitted with a switch can be remotely reconfigured as either a prepayment or a credit meter allowing customers to easily switch contracts.

vii) Prosumers

Small scale, decentralized generation of energy, like solar and wind-power technology will become more important in future. The traditional customer role will change as he becomes at times either an energy producer (selling surplus energy generated locally) or a consumer (“Prosumer”). Smart meters can support this process by measuring not just the energy consumed but also the energy generated, and can communicate this data instantly.

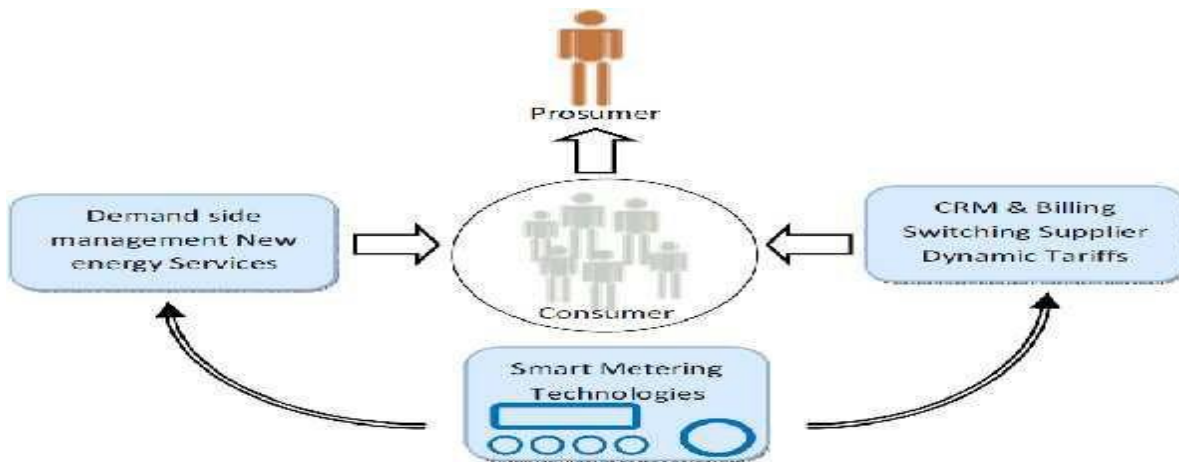

Figure 8.5: Smart Metering features

3) RUNNING ENERGY BUSINESSES BETTER

Smart Metering will transform the way that utilities run their businesses and reduce their costs to serve, with major benefits for them and their customers.

i) Improved billing process

The ability to remotely read meters will lead to fewer complaints about bills and allow customer service agents to check meter readings live whilst dealing with an enquiry. In return for investing in Smart Metering, the energy company will incur lower costs for reading meters, especially those in hard-to-access properties.

ii) Supplier switching

In competitive markets Smart Metering will support customers in switching more easily between suppliers. The meters can be read easily when the contract changes so that the process

can be carried out in 24 hours.

iii) Meter management

Smart Meters can be remotely disconnected and the firmware can be updated without entering the site, offering greater convenience to the energy company and customer.

iv) Fraud/Revenue protection

Smart Meters can offer more sophisticated fraud detection techniques, protecting income for the Energy Company and keeping prices down for the customer.

v) Network management

Through real-time consumption data and aggregation of consumer profiles Smart Metering allows for a more precise forecast of energy consumption which improves the network management and planning processes.

4) MULTI-UTILITIES

Smart Metering applies to other utilities just as much as electricity. Smart Meters can be provided for gas, heat and cooling as well as water. Smart Metering for other utilities can be provided as separate systems run in parallel or they can share infrastructure thus allowing for synergies which will lead to reduction in the costs to serve. For instance the electricity meter can collect data from the gas meter and provide a communications channel to the gas utilities back office.

5) RENEWABLE AND DISTRIBUTED GENERATION

Smart Metering can be used to integrate the growing number of embedded renewable generators, such as wind and photovoltaic. Smart Metering systems can readily be set up to measure exported power, when the customers use less power than they generate. They can also measure the output of the generator and supply this data to the energy company to provide a complete picture of the generator's performance.

SMART METERING APPLICATIONS

1. Meter Data Management System (MDMS)

A Meter Data Management System (MDMS) collects and translates meter data into information. Key benefits of an MDMS include:

- Helping the utility meet the challenges of processing and managing metering data
- Providing a single repository for this data with a variety of analysis capabilities

to facilitate the integration with other utility information systems. Solutions based on meter data include the following:

- Smart meter deployment planning and management
- Meter and network asset monitoring and management
- Automated smart meter provisioning (i.e. Addition, Deletion and Updating of Meter information at utility and AMR side) & billing cutover
- Meter-to-Cash; including complex billing determinants for legacy Customer Information Systems (CIS) and billing systems that cannot perform complex calculations of interval data and rate structures
- More accurate Customer Service and invoicing information
- Automated validation, editing, and estimation (VEE) of meter data
- Transmit meter data outside of their organization to Counter parties
- Provide Settlement Statements and auditing information
- Provide information to create Executive Level Reports
- Revenue Protection business processes automation and reporting
- Data Aggregation for network loss and theft detection
- Outage detection and event management
- Remote connect and disconnect of accounts reducing truck rolls
- Customer information portal, use and billing analysis applications

SMART METERS: AN OVERVIEW OF THE HARDWARE

The replacement of electro-mechanical meters with electronic meters offers several benefits. Electronic meters not only can measure instantaneous power and the amount of energy consumed over time but also other parameters such as power factor, reactive power, voltage and frequency, with high accuracy. Data can be measured and stored at specific intervals.

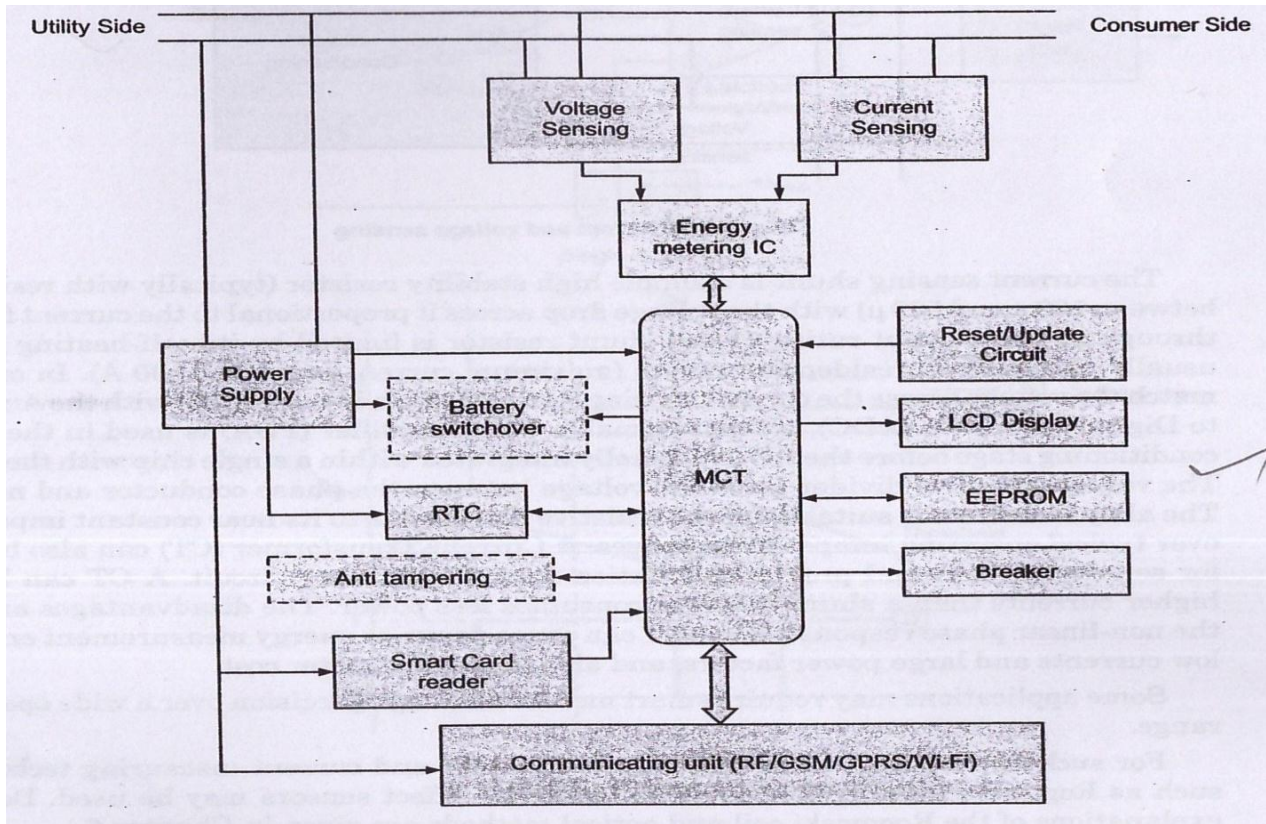

Fig 3.23 Hardware Structure of Smart Meter

Moreover, electronic meters are not sensitive to external magnets or orientation of the meter itself, so they are more tamper proof and more reliable. Early electronic meters had a display to show energy consumption but were read manually for billing purposes. More recently electronic meters with two-way communications have been introduced. Fig. 3.22 provides a general functional block diagram of a smart meter. In the smart meter architecture has been split into five sections: signal acquisition, signal conditioning, Analogue to Digital Conversion (ADC), computation and communication.

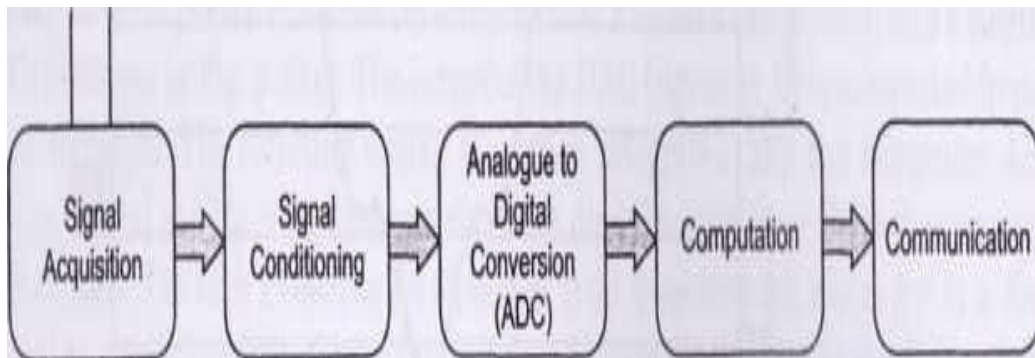
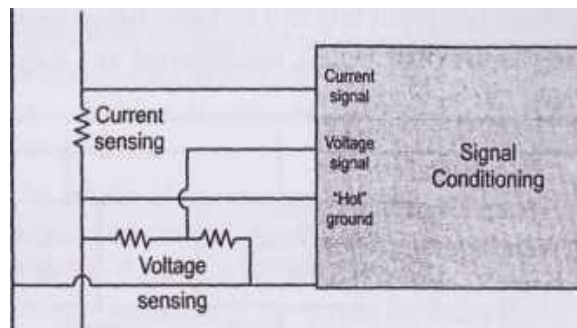

Fig 3.22 Electronic meters with Two-way communications

1. Signal Acquisition

A core function of the smart meter is to acquire system parameters accurately and continuously for subsequent computation and communication. The fundamental electrical parameters required are the magnitude and frequency of the voltage and the magnitude and phase displacement (relative to the voltage) of current. Other parameters such as the power factor, the active/reactive power, and Total Harmonic Distortion (THD) are computed using these fundamental quantities. Current and voltage sensors measure the current into the premises (load) and the voltage at the point of supply. In low-cost meters the measuring circuits are connected directly to the power lines, typically using a current-sensing shunt, resistor on the current input channel and a resistive voltage divider on the voltage input channel Fig. 3.2.4.



2. Signal Conditioning

The signal conditioning stage involves the preparation of the input signals for the next step in the process, ADC. The signal conditioning stage may include addition/subtraction, attenuation/amplification and filtering. When it comes to physical implementation, the signal conditioning stages can be realized as discrete elements or combined with the ADC as part of an Integrated Circuit. Alternatively the stages can be built into 'System on a Chip' architecture with a number of other functions.

In many circumstances the input signal will require attenuation, amplification or the addition/subtraction of an offset such that its maximum magnitude lies within the limits of the inputs for the ADC stage. To avoid inaccuracy due to aliasing, it is necessary to remove components of the input signal above the Nyquist frequency.

3. Analogue to Digital Conversion

Current and voltage signals obtained from the sensors are first sampled and then digitized to be processed by the metering software. Since there are two signals (current and voltage) in a single phase meter, if a single ADC is used, a multiplexer is required to send the signals in turn to the

ADC. The ADC converts analogue signals coming from the sensors into a digital form. As the number of levels available for analogue to digital conversion is limited, the ADC conversion always appears in discrete form.

There are many established methods for conversion of an analogue input signal to a digital output. The majority of the methods involve an arrangement of comparators and registers with a synchronizing clock impulse. The most common ADCs for metering use the successive approximation and the sigma-delta method.

4. Computation

The computation requirements are split into arithmetic operations on input signals, time stamping of data, preparation of data for communication or output peripherals, handling of routines associated with irregular input (such as payment, tamper detection), storage of data, system updates and coordinating different functions. The block diagram shown in Fig. 3.29 shows different functional blocks associated with the computation functions of a smart meter.

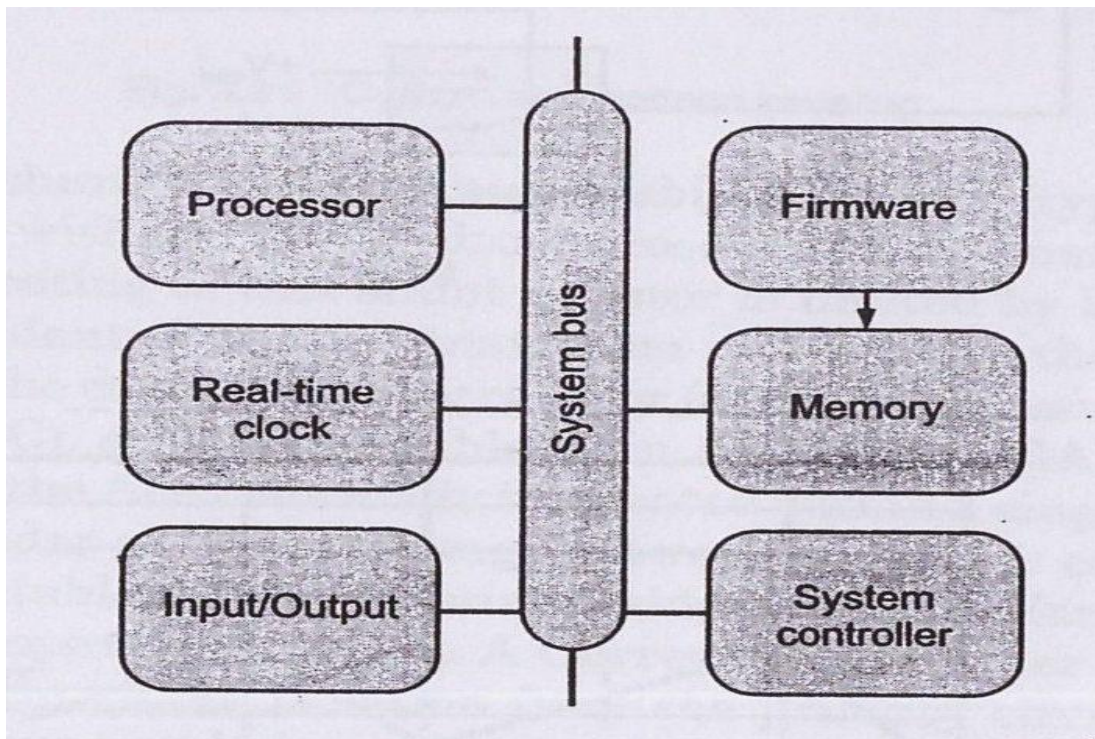

Due to the relatively large number of arithmetic operations (Table 5.2) required for the derivation of the parameters, a Digital Signal Processor (DSP) is used. In addition to routine arithmetic operations, a meter deals with a large number of other procedures (that is, payment, tamper detection, system updates, user interactions) as well as other routine tasks (for example, the communication of billing information). Therefore, a high degree of parallelism (the ability to

perform multiple tasks, involving the same data sets, simultaneously) and/or buffering (the ability to temporarily pause arithmetical operations so that other needs can be attended to) is required.)

For computation, volatile memory (where information is lost on loss of power supply) and non-volatile memory is needed. Volatile memory is used for temporary storage of data to support the processors) as operations are undertaken. The amount of volatile memory used depends on the quantity, rate and complexity of computation and the rate of communication to/from ports. A certain amount of non-volatile memory is typically required to store specific information, such as the unit serial number and maintenance access key codes. Additionally data related to energy consumption should be retained until successful communication to the billing company has been achieved.

5. Input/Output

A smart meter has a display that presents information in the form of text and graphs for the human user. Liquid Crystal Displays (LCD) and the Light Emitting Diodes (LED) are preferred for their low cost and low power consumption requirements. Both display types are available in seven-segment, alphanumeric and matrix format. LEDs are relatively efficient light sources, as they produce a significant amount of light when directly polarized (at relatively low voltages: 1.2—1.6 V), and a current of a few milliamps is applied. Smart meters provide a small key pad or touch screen for human-machine interaction, for instance, to change the settings of a smart meter so as to select the smart appliance to be controlled or to select payment options.

6. Communication

Smart meters employ a wide range of network adapters for communication purposes. The wired options include the Public Switched Telephone Network (PSTN), power line carrier, cable modems and Ethernet. The wireless options include ZigBee, infrared, and GSM/GPRS/CDMA Cellular.

Example 3.1

The specification sheet of a smart meter states that its rated current is 100 A and power dissipation is 3 W. It employs a current-sensing resistor of $200\mu\Omega$. When the load current is the rated value of the meter, calculate:

- i) the power dissipation in all the other components of the meter;**
- ii) the voltage across the current-sensing resistor;**
- iii) the gain of the PGA to match with an ADC having a full scale of 5 V.**

Answer

i) The power dissipated in the current-sensing resistor is given by:

$$PR = I^2 R = (100)^2 \times 200 \times 10^{-6} = 2 \text{ W}$$

Therefore, the power consumed by other components (the microcontroller, display, and so on) is:

$$\text{Pre-main} = (3 - 2) \text{ W} = 1 \text{ W}$$

ii) Voltage across the current-sensing resistor at full-load current is:

$$I \times R = 100 \times 200 \times 10^{-6} = 0.02 \text{ V}$$

iii) Gain of the PGA = $5/0.02 = 250$.

Example 3.2

A smart meter displays current harmonic measurements up to the 5th harmonic component, What should be the minimum sampling frequency used in the signal conditioning stage? Assume that the frequency of the supply is 50 Hz.

Answer

The frequency of the 5th harmonic component = $5 \times 50 \text{ Hz} = 250 \text{ Hz}$. In order to capture up to 5th harmonic component, the signal should be filtered by an anti-aliasing filter with a cut-off frequency of 250 Hz.

According to the Nyquist criteria, the minimum sampling frequency should then be at least = $2 \times 250 \text{ Hz} = 500 \text{ Hz}$. This is shown in Fig. 3.30, where f_s is the sampling frequency.

Example 3.3

A smart meter uses the same 16-bit analogue to digital converter for both current and voltage measurements. It uses a 100 : 5 A CT for current measurements and 415: 10 V potential divider for voltage measurements. When the meter shows a current measurement of 50 A and a voltage measurement of 400 V, what is the maximum possible error in the apparent power reading due to the quantization of the voltage and current signals?

Answer

Current range to the ADC: 0-5 A

Resolution of the ADC: $5/2^{16} = 76 \mu\text{A}$

So the maximum quantization error of the current is 76 μA .

50 A passes through the primary of the CT and so the ADC reads: $50 \times 5/100 = 2.5 \text{ A}$

Voltage range to the ADC: 0-10 V

Resolution of the ADC: $10/2^{16} = 152 \mu\text{V}$

The apparent power reading is:

$$((V + \Delta V)(I + \Delta I) = VI + \Delta I \cdot V + I \cdot \Delta V + \Delta I \cdot \Delta V) = VI + \Delta I \cdot V + I \cdot \Delta V$$

So the maximum quantization error of the voltage is $152 \mu\text{V}$.

400 V is read by voltage divider and so the ADC reads; $400 \times 10/415 = 9.64 \text{ V}$

Therefore, the maximum possible error in the apparent power reading due to the quantization is:

$$V\Delta I + I\Delta V = 9.64 \times 76 \times 10^{-6} + 2.5 \times 152 \times 10^{-6} = 1.11 \text{ mVA.}$$

CATEGORY OF SMART METERS

Smart Meter Systems are varied in technology and design but operate through a simple overall process. The Smart Meters collect data locally and transmit via a Local Area Network (LAN) to a data collector. This transmission can occur as often as 15 minutes or as infrequently as daily according to the use of the data. The collector retrieves the data and may or may not carry out any processing of the data. Data is transmitted via a Wide Area Network (WAN) to the utility central collection point for processing and use by business applications. Since the communications path is two-way, signals or commands can be sent directly to the meters, customer premise or distribution device.

Basic Types of Smart Meter Systems

There are two basic categories of Smart Meter system technologies as defined by their LAN. They are Radio Frequency (RF) and Power Line Carrier (PLC). Each of these technologies has its own advantages and disadvantages in application. The utility selects the best technology to meet its demographic and business needs. Factors that impact the selection of the technology include evaluation of existing infrastructure; impact on legacy Equipment, functionality, technical requirements as well as the economic impact to the utility's customers. The selection of the technology requires a thorough evaluation and analysis of existing needs and future requirements into a single comprehensive business case.

1. Radio Frequency - RF

Smart Meter measurements and other data are transmitted by wireless radio from the meter to a collection point. The data is then delivered by various methods to the utility data systems for processing at a central location. The utility billing, outage management, and other systems use the data for operational purposes. RF technologies are usually two different types.

i).Mesh Technology

The smart meters talk to each other (hop) to form a LAN cloud to a collector. The collector transmits the data using various WAN methods to the utility central location.

a) Mesh RF Technologies advantages include acceptable latency, large bandwidth, and typically operate at 9157 MHz frequencies.

b) Mesh technologies disadvantages include terrain and distance challenges for rural areas, proprietary communications, and multiple collection points.

ii)Point-to-Point Technology

The smart meters talk directly to a collector, usually a tower. The tower collector transmits the data using various methods to the utility central location for processing.

- Point-to-Point RF technologies advantages include little or no latency direct communication with each end point, large bandwidth for better throughput, some are licensed spectrum, and can cover longer distances.
- The disadvantages of point-to-point RF networks are licensing (not for 900 MHz), terrain may prove challenging in rural areas (Line of Sight), proprietary communications used for some technologies, and less interface with DA devices.

2.Power Line Carrier (PLC)

Smart Meter measurements and other data can be transmitted across the utility power lines from the meter to a collection point, usually in the distribution substation feeding the meter. Some solutions have the collection point located on the secondary side of a distribution transformer. The data is then delivered to the utility data systems for processing at a central location. The utility billing, outage management, and other systems use the data for operational purposes.

- PLC technology advantages include leveraging the use of existing utility infrastructure of poles and wires, improved cost effectiveness for rural lines, more effective in challenging terrain, and the capability to work over long distances.
- PLC disadvantages include longer data transmit time (more latency), less bandwidth and throughput, limited interface with Distribution Automation (DA) devices, and higher cost in urban and suburban locations.

AUTOMATIC METER READING (AMR)

It is a process of digitally “noting” the energy meter readings. This process eliminates the traditional paper and pen” and the errors associated with manual reading/recording/processing of the meter data. AMR also makes the data recording fast and saves on time and hence complies with the definition of automation. The AMR can be further classified based on the distance between the meter reading station and the target meter. Firstly, the local-AMR wherein a meter man goes to read the meter with a hand held device (MRI) for collecting the readings and secondly, remote AMR in which the meter is dialed from the central office using appropriate modems to collect the meter reading from a distance. The pre-qualifier to both the AMR’s is the communication ability of the energy meter. Meter readings is the feedback loop for the utility’s efficient operation and besides completing the revenue cycle, the meter reading provides vital data for the utility operations like billing, energy audit, tariff formulation, electricity regulator. Load research, grouping of feeder etc.

One of the disadvantages of the AMR system is that it involves limited, one-way communication, typically through mobile radio frequency where information is collected by a vehicle passing by the equipment or, in some cases, a one-way data system being passed back to a vendor's back office systems. Also functionalities are generally limited to monthly meter reads, tamper reporting, data aggregation, load profiling, and meter diagnostic reporting.

ADVANCED METERING INFRASTRUCTURE (AMI)

Advanced Metering Infrastructure (AMI) facilitates monitoring and measurement of consumer information through Smart Meters installed at customer premises. The information is transferred to utility control centre through communication mode such GPRS / PLC / RF. Smart meters will also enable Time of Day (TOD) and Critical Peak pricing (CPP)/Real Time Pricing (RTP) rate metering and monitoring based on energy consumption.

Main features of AMI are:

- Recording energy consumption data for consumer and utility (kWh, kVARh voltage, pf, max demand etc.)
- Automatically send the consumption data to the utility at pre-defined intervals.
- Time-based pricing signal for Demand Response.
- Bi-directional communication ability.
- Net metering to facilitate integration of Distributed Generation in the form of Roof Top Solar etc.

- Loss of power (and restoration) event notification.
- Remote Load limiting for Peak Load management.
- Remote connection and disconnection of individual supply.
- Energy prepayment.
- Reporting meter tampering in real time to the utility.
- Communications with other intelligent devices in the home.
- Gateway to communicate other meters data (Gas/water).

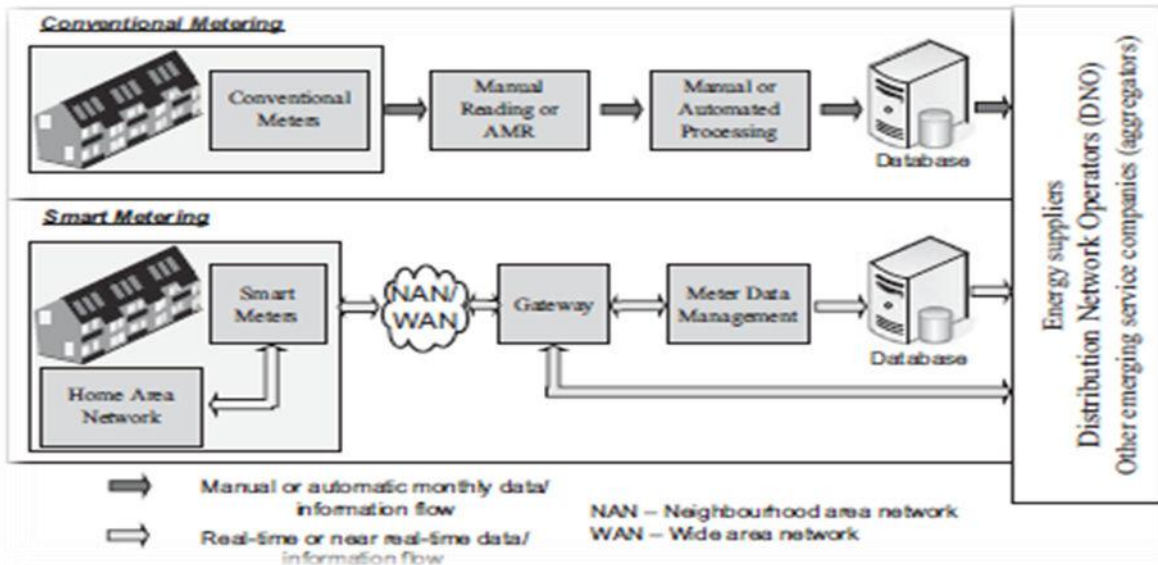

Figure3.3 : Conventional meter Vs smart meter

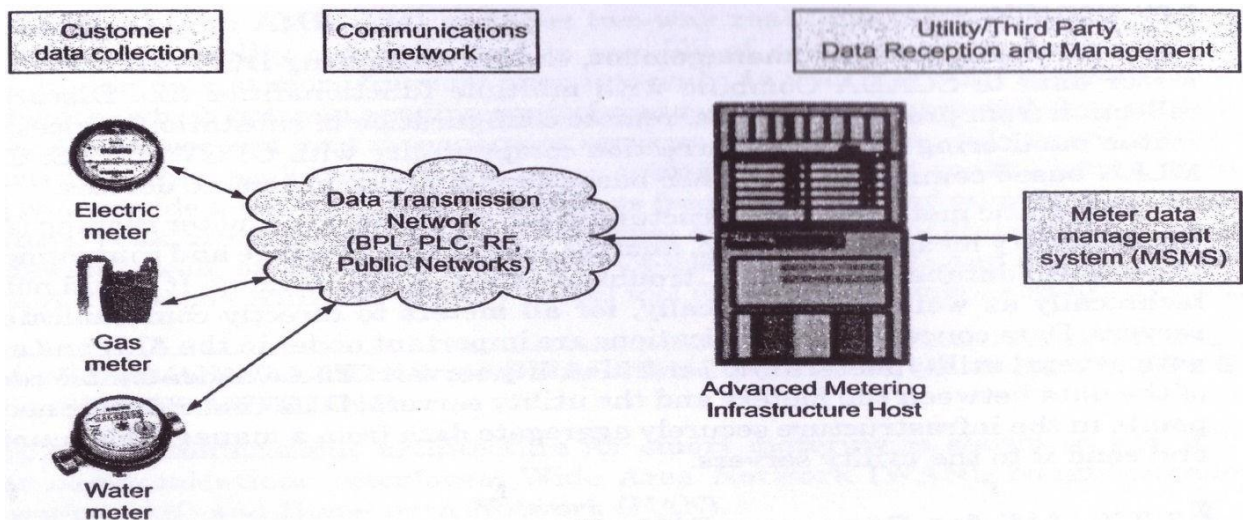

Fig ADVANCED METERING INFRASTRUCTURE (AMI)

AMI is a more advanced AMR system that involves two-way communication. They are capable of measuring and recording energy consumption in short intervals. Using this technology, the energy providers can read and control features of the meter remotely. AMI stores more

information, and provides more detailed information on usage. AMI includes the communication hardware, software, associated data retrieval and data management systems. Figure 8.3 shows the broad difference between a conventional meter and a smart meter. AMI allows increased functionality to also include integrated disconnect, ability to implement advanced time-based rates, distributed generation detection and control, remote meter programming, power quality monitoring and reporting, home area network interfaces, and enhanced security compliance. Functionalities are expanded to include features such as daily or on-demand meter reads of hourly interval data, outage notification flags, and other commodity reads. It is a pivotal information source that, when used effectively, can drive enterprise efficiencies and benefits throughout the distribution business, including:

- Increased revenue & reduced impact of price volatility
- Increased customer satisfaction
- Increased distribution system & service reliability
- Enabling Demand Response (DR) & Smart Grid technologies
- Improved load forecasting and modeling, system planning & engineering
- Enhanced water & gas leakage detection
- Improved transformer load management

Smart Metering offers consumers, suppliers, network operators, generators and regulators a wide range of useful tools and services enabling ultimately a smarter energy world. Generally, Smart Metering technologies consist of several different technical components which may vary according to the specific market conditions in different Member States, but the majority includes the following features:

1. Accurate measurement and transmission of electricity, gas, water or heat consumption data
2. Provision of a two-way information gateway and communication infrastructure between the meters and relevant parties and their systems, for:

- Raising awareness and empowering the consumer through delivery of actual consumption data
- Improving Customer Relationship Management (CRM) and services, including automated billing/invoicing based on detailed metering data
- Managing energy networks/grids better by shifting or reducing energy consumption, e.g. through Demand Side Management (DSM)
- Encouraging decentralized, micro-generation of energy, thus transforming the consumer into an energy producer (“Prosumer”)

ADVANCED METERING INFRASTRUCTURE BENEFITS & DRIVERS

The power grid has become a necessity in the modern society. Without a stable and reliable power grid, tens of millions of people's daily life will be degraded dramatically. With the development of information system and communication technology, many countries have been modernizing the aging power system into smart grid, which is featured with two way transmission, high reliability, real-time demand response, self-healing, and security. Within smart grid, Advanced Metering Infrastructure (AMI) plays a vital role and is associated with people's daily life most closely.

AMI encompasses a whole electricity information network including Smart Meters on customer houses, communications to and from a utility, and eventually, communication to devices within a customer's home.

Advanced Metering Infrastructure comprises three key elements: Smart Meters, Meter Communication Infrastructure and Data Management. The combination of all three is vital to the development of a smart grid.

- Smart Meter Provides two-way communication between customer and utility, enabling functions such as outage detection, real time pricing and power quality monitoring.
- Meter Communication Infrastructure Describes the various methods of communication between meter and utility. These include power line communication (PLC), cellular (broadband or GPRS) and radio frequency (RF).
- Data Management Broadly covers managing all the data created by the meter - this includes transfer, storage and protecting privacy.

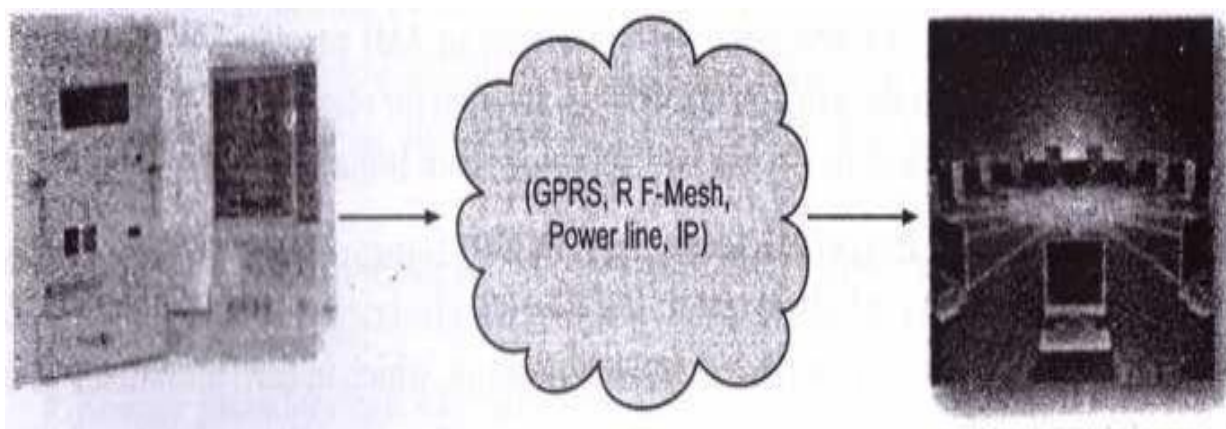

BENEFITS

The benefits of AMI are multifold and can be generally categorized as:

- **Operational Benefits:** AMI benefits the entire grid by improving the accuracy of meter reads, energy theft detection and response to power outages, while eliminating the need for on-site meter reading.
- **Financial Benefits:** AMI brings financial gains to utility, water and gas companies by reducing equipment and maintenance costs, enabling faster restoration of electric service during outages and streamlining the billing process.
- **Customer Benefits:** AMI benefits electric customers by detecting meter failures early, accommodating faster service restoration, and improving the accuracy and flexibility of billing. Further, AMI allows for time-based rate options that can help customers save money and manage their energy consumption.
- **Security Benefits** - AMI technology enables enhanced monitoring of system resources, which mitigates potential threats on the grid by cyber-terrorist networks.

DRIVERS

Despite its widespread benefits, deploying AMI presents three major challenges that include high upfront investments costs, integration with other grid systems, and standardization.

1. **High Capital Costs:** A full scale deployment of AMI requires expenditures on all hardware and software components, including meters, network infrastructure and network management software, along with cost associated with the installation and maintenance of meters and information technology systems.
2. **Integration:** AMI is a complex system of technologies that must be integrated with utilities' information technology systems, including Customer Information Systems (CIS), Geographical Information Systems (GIS), Outage Management Systems (OMS), Work Management (WMS), Mobile Workforce Management (MWM), SCADA/DMS, Distribution Automation System (DAS), etc.
3. **Standardization:** Interoperability standards need to be defined, which set uniform requirements for AMI technology, deployment and general operations and are the keys to successfully connecting and maintaining an AMI-based grid system.

AMI IN THE INDIAN CONTEXT

Modernizing India's grid system by investing in AMI promises to mitigate a number of strains placed on the grid due to growing demand for electric, gas and water resources. In particular, AMI will improve three key features of India's grid system including:

1. **System Reliability:** AMI technology improves the distribution and overall reliability of electricity by enabling electricity distributors to identify and automatically respond to electric demand, which in turn minimizes power outages.

2. **Energy Costs:** Increased reliability and functionality and reduced power outages and streamlined billing operations will dramatically cut costs associated with providing and maintaining the grid, thereby significantly lowering electricity rates.

3. **Electricity Theft:** Power theft is a common problem in India. AMI systems that track energy usage will help monitor power almost in real time thus leading to increased system transparency.

AMI modernizes the electricity metering system by replacing old mechanical meters with smart meters, which provide two-way communications between utility companies and energy customers. With the AMI, people can not only read the meter data remotely, but also do some customized control and implement fine-coarse demand response. In addition, the real-time data collected from the smart meters can improve the reliability of the distribution grid by avoiding line congestion and generation overloads. The utility companies can also provide faster diagnosis of outage and dynamical electricity price thanks to the AMI

Advanced Metering Infrastructure (AMI) is an approach to integrating consumers based upon the development of open standards. It provides consumers with the ability to use electricity more efficiently and provides utilities with the ability to detect problem on their systems and operate them more efficiently.

AMI enables consumer-friendly efficiency concepts like "Prices to Devices" to work like this: Assuming that energy is priced on what it costs in near real-time - a Smart Grid imperative - price signals are relayed to "smart" home controllers or end-consumer devices like thermostats, washer/dryers and refrigerators - the home's major energy-users. The devices, in turn, process the information based on consumers' learned wishes and power accordingly. The house or office responds to the occupants, rather than vice versa. Because this interaction occurs largely "in the

background,” with minimal human intervention, there’s a dramatic savings on energy that would otherwise be consumed. This type of program has been tried in the past, but without Smart Grid tools such as enabling technologies, interoperability based on standards, and low-cost communication and electronics, it possessed none of the potential that it does today. Consider grid visualization and the tools associated with it. Already used for real-time load monitoring and load-growth planning at the utility level, such tools generally lack the ability to integrate information £ from a variety of sources or display different views to different users. The result: Limited situational awareness. This condition will grow even more acute as customer focused ^ efficiency and demand response programs increase, requiring significantly more data as well as the ability to understand and act on that data.

Next-generation visualization is on its way. Of particular note is VERDE (Visualizing Energy Resources Dynamically on Earth), a project in development for DOE at the Oak Ridge National Laboratory. VERDE will provide wide-area grid awareness, integrating real time sensor data, weather information and grid modeling with geographical information. Potentially, it will be able to explore the state of the grid at the national level and switch within seconds to explore specific details at the street level. It will provide rapid information about blackouts and power quality as well as insights into system (W operation for utilities. With a platform built on Google Earth, it can also take advantage of content generated by Google Earth’s user community.

However, rich information exchange and hierarchical semi-open network structure in AMI extend the attack surface for metering to entire public networks and introduce much vulnerability for cyber-attacks. Among all the attacks to the AMI, energy theft in emerging economies has been a widespread practice, both in developing countries and developed countries. A World Bank report finds that up to 50% of electricity in developing countries is acquired via theft. It is reported that each year over 6 billion dollars are lost due to the energy theft in the United States alone. In 2009, the FBI reported a wide and organized energy-theft attempt that may have cost up to 400 million dollars annually to a utility following an AMI deployment. In Canada, BC Hydro reports \$100 million in losses every year. Utility companies in India and Brazil incur losses around \$4.5 billion and \$5 billion due to electricity theft, respectively. There is even a video which shows how to crack the meter and cut the electricity bill in half on Youtube.

As a result, energy-theft issue becomes one of the most important concerns which prohibit the development of AML Due to the nature of non-technical loss during transmission of electrical

energy, it is very difficult for the utility companies to detect and fight the people responsible for energy theft. The unique challenges for energy theft in AMI call for the development of effective detection techniques. However, so far, few studies have elaborated what have been achieved and what should be done for these challenges.

As a result, we are motivated to investigate energy-theft issue in AMI, which is of critical importance to the design of AMI information networks and has been considered as one of the highest priorities for the smart grid design.

AMI SYSTEM MODEL

The advanced metering infrastructure is a hierarchical structure. As shown in Fig. 3.6, AMI is comprised of a number of different networks communicating with each other, and these networks are described as follows:

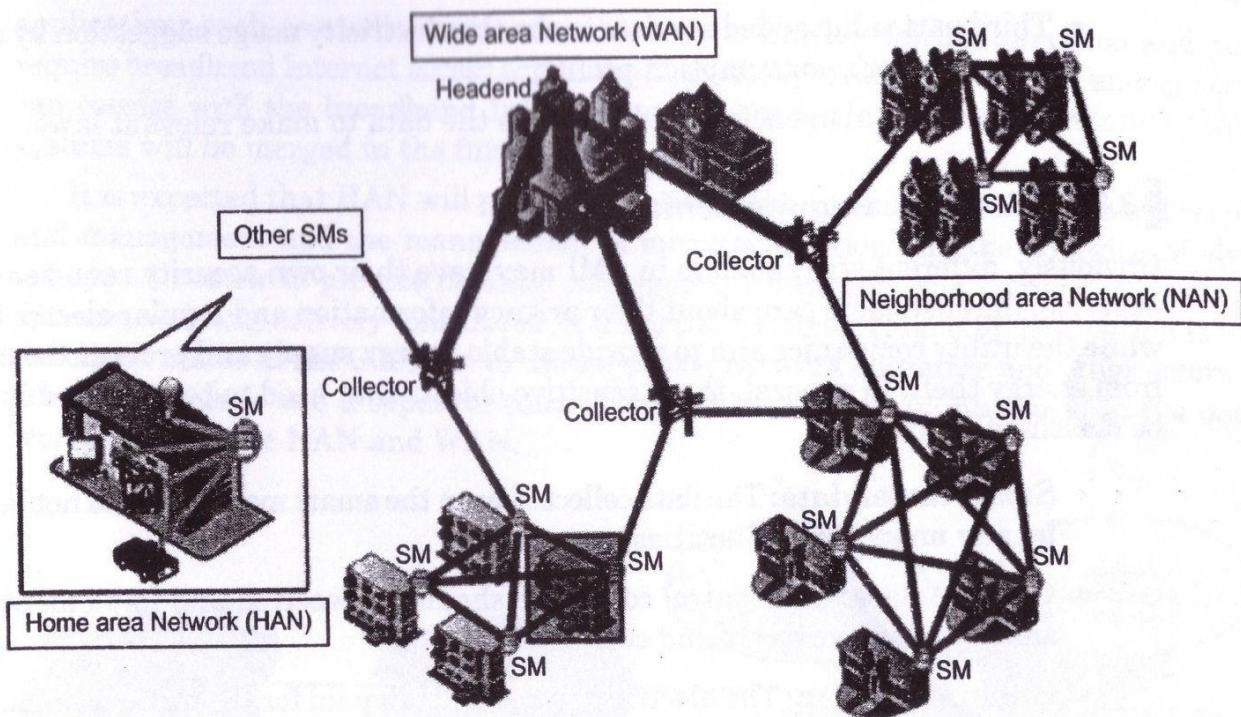

- Home Area Network (HAN): The home area network is a kind of local area network with smart meter as its core. Household appliances can connect to the smart meter through wireless channel, e.g., ZigBee, which conveniently enables people to monitor and control the use of household appliances and make proper and economical usage plans.
- Neighborhood Area Network (NAN): The neighborhood area network is a network which is comprised of neighboring smart meters. A collector in NAN takes charge of the

aggregation of metering data from smart meters, and the popular WiFi technology is suggested for NAN. Certainly, other technologies such as WiMAX and 3G/4 G cellular can also be used for NAN communication.

- Wide Area Network (WAN): The wide area network serves as a connection of collectors in NAN and head ends in the utility control center. Since millions of metering data are transferred in the WAN, the requirements of both bandwidth and reliability of the network are extremely high. As a result, the main communication technology suggested in WAN is optic fiber, although microwave and cellular are also considered for WAN as optional technologies. The metering data continuously generated by smart meter can be used by various grid stakeholders to offer efficient services as follows:
 - Customers can know exactly how much electricity they have consumed at any time and adjust their electricity consumption according to the dynamic electricity price;
 - Grid operators can make smooth operation of the power system based on the real time metering data;
 - Energy providers can estimate the mid-term power consumption according to the aggregated data;
 - Billing companies need precise power consumption data to implement flexible electricity price model;
 - Third part value added services can make electricity usage suggestion by analyzing the customer's consumption profile;
 - Governmental agencies need to access the data to make relevant laws.

Security Requirements

Obviously, different stakeholders in AMI may have their own security requirements. For example, the customers care about their privacy information and regular electricity usage; while the utility companies aim to provide stable energy supply and prevent the customers from energy theft. In general, those sensitive objects that need to be protected in AMI can be classified as follows:

- **Smart meter data:** The data collected from the smart meters should not be accessed by any unauthorized entities;

- **Control data:** The control command should be received and implemented by the smart meters correctly and completely;
- **Bill information:** The electricity price and bill paid for the utility company should not be manipulated by unauthorized entities;
- **Customer's personal information:** The information includes customer's credit card information, daily electricity usage profile, and so on.

Based on the above sensitive objectives, security requirements for AMI can be classified as follows:

- **Confidentiality:** Sensitive information should only be accessed by authorized entities;
- **Integrity:** Data transmitted in the AMI must be authentic and correctly reflect the source data without any unauthorized manipulation.
- **Availability:** Data in AMI should be accessible by authorized entities whenever they need the data;
- **Non-repudiation:** The entities cannot deny receiving anything, such as renewed electricity price, that they have received; and cannot clarify that they have sent some data, e.g., electricity amount they have consumed, which they actually do not send;
- **Privacy:** The entities cannot infer any private information from the published metering data.

ADVANTAGES OF AMI OVER AMR

AMI can be considered as an advanced version of Automated Meter Reading (AMR). AMR has been used by utilities in various countries since the early 1990s, in order to remotely collect periodic readings from gas or electric meters. AMR systems are one-way systems, used to provide the collection of data on monthly or daily basis and are not capable of broadcasting control messages, unlike AMI systems.

Compared with AMR, AMI provides two-way real-time communication between the meter and the utility company and is capable of collecting and distributing energy consumption data at more frequent time intervals. In addition, AMI systems have higher bandwidth, which helps in sending control messages to customers and thus contributes to demand-response and load management services. AMR systems only provide data related to meter reading, peak

demand and other such limited power quality information, while AMI can provide a list of information such as frequent daily and cumulative energy usage readings, peak demand measurements, logging of voltage and voltage-related events such as sags and swell, outage counts, and time-of-use energy usage and tamper notifications. Thus, AMI is a powerful and broadly useful tool for both consumers and utility companies.

COMMUNICATIONS INFRASTRUCTURE AND PROTOCOLS FOR SMART METERING

A typical communications architecture for smart metering is shown in Fig. 3.7. It has three communications interfaces: Wide Area Network (WAN), Neighborhood Area Network (NAN) and Home Area Network (HAN).

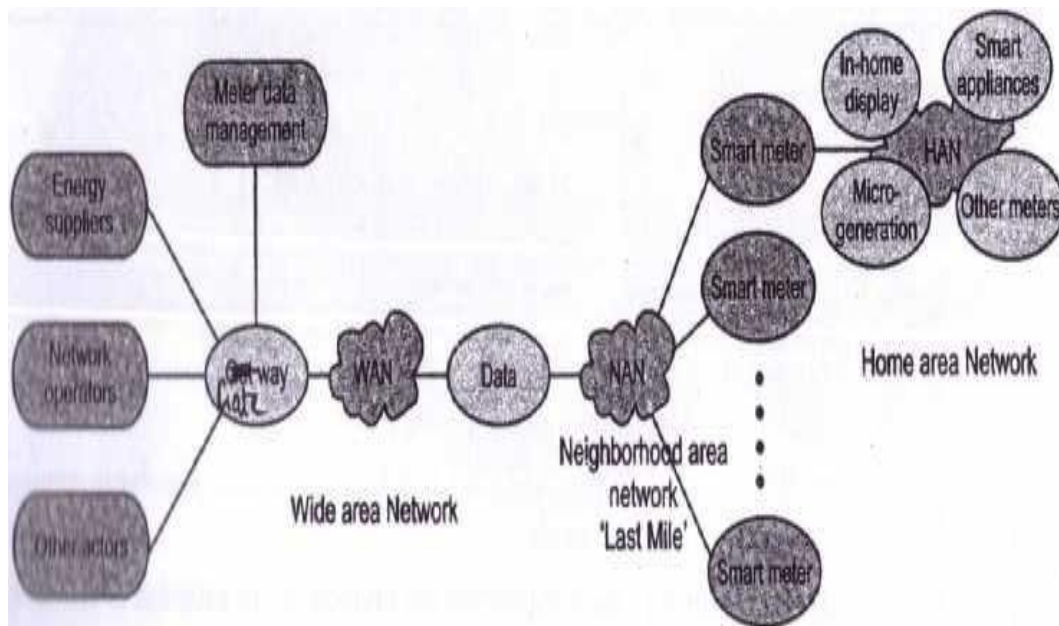

Fig 3.7

1. Home-area Network

A Home-Area Network (HAN) is an integrated system of smart meter, in-home display, micro generation, smart appliances, smart sockets, HVAC (Heating, Ventilation, Air Conditioning) facilities and plug-in hybrid/electric vehicles. A HAN uses wired or wireless communications and networking protocols to ensure the interoperability of networked appliances and the interface to a smart meter. It also includes security mechanisms to protect consumer data and the metering System.

A HAN enables centralized energy management and services as well as providing different facilities for the convenience and comfort of the household. Energy management functions provided by HAN include energy monitoring and display, controlling the HVAC system and controlling smart appliances and smart plugs. The services provided by HAN for the convenience of the household can include scheduling and remote operation of household appliances as well as household security systems. Home-based multimedia applications such as media Centre's for listening to music, viewing television and movies require broadband Internet access across the HAN. A separate HAN used for energy services can coexist with the broadband Internet system but there is some expectation that the systems will be merged in the future.

It is expected that HAN will provide benefits to the utilities through demand response and management and the management of micro-generation and the charging of electric vehicles. In order to provide demand management functions and demand response, two options are being actively considered in different countries (Fig. 3.8). One option is to use the smart meter as the interface to the suppliers, network operators and other actors. The other option is to use a separate control box, which is directly interfaced to the outside world through the NAN and WAN.

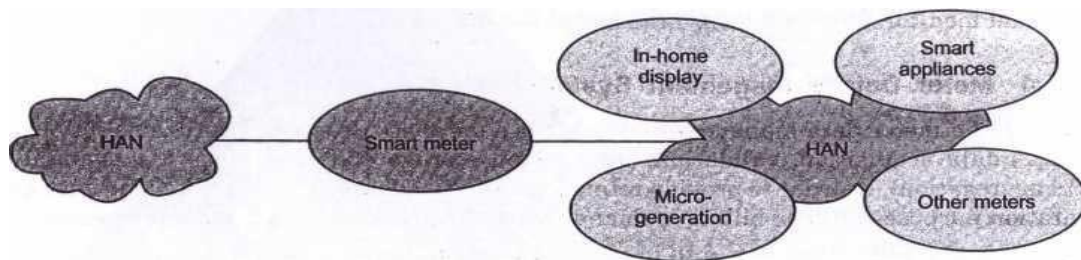

Fig a) Meter act as an Interface

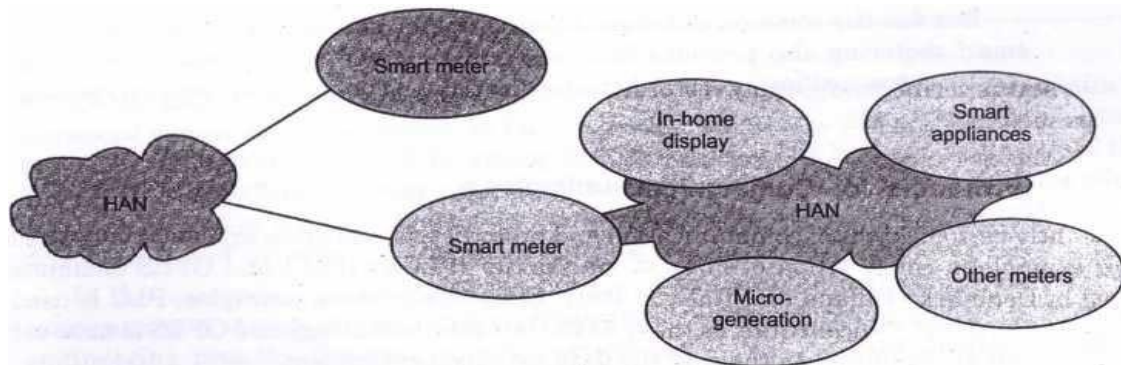

Fig b) Controller act as an Interface

i) Neighborhood Area Network

The primary function of the Neighborhood Area Network (NAN) is to transfer consumption readings from smart meters. The NAN should also facilitate diagnostic messages, firmware upgrades and real-time or near real-time messages for the power system support. It is anticipated that the data volume transferred from a household for simple metering is less than 100 kB per day and firmware upgrades may require 400 kB of data to be transferred.

However, these numbers will escalate rapidly if different real-time or near real-time smart grid functions are added to the smart metering infrastructure.

The communication technology used for the NAN is based on the volume of data transfer. For example, if ZigBee technology which has a data transfer rate of 250 kB/s is used, then each household would use the communication link only a fraction of a second per day to transfer energy consumption data to the data concentrator. Household would use the communication link only a fraction of a second per day to transfer energy consumption data to the data concentrator.

ii) Data Concentrator

The data concentrator acts as a relay between the smart meters and the gateway. It manages the meters by automatically detecting them, creates and optimizes repeating chains (if required to establish reliable communication), coordinates the bi-directional delivery of data, and monitors the conditions of the meters.

iii) Meter Data Management System

The core of a meter data management system is a database. It typically provides services such as data acquisition, validation, adjustment, storage and calculation (for example, data aggregation), in order to provide refined information for customer service and system operation purposes such as billing, demand forecasting and demand response.

A major issue in the design and implementation of a meter data management system is how to make it open and flexible enough to integrate to existing business/enterprise applications and deliver better services and more value to customers while ensuring data security.

Besides the common database functionalities, a meter data management system for smart metering also provides functions such as remote meter connection/disconnection, power status verification, supply restoration verification and on-demand reading of remote smart meters.

Protocols for Communications

Currently various kinds of communication and protocol types are used for smart metering. For example, a combination of Power Line Carrier (PLC) and GPRS communication is used in Denmark, Finland and Italy. In these European examples, PLC is used between the meter and data concentrator as the last mile technology and GPRS is used between the concentrator and gateway to the data management system.

Table 3.1 summarizes the characteristics of the most commonly used protocols for demand side applications, including local AMR, remote AMR, smart metering and home area automation. In Table 3.1, means applicable, and a blank means not applicable or the information is still not available. With local AMR, the meter readings are collected by staff using hand-held devices and with remote AMR the meter readings are collected from a distance through communication links. For most protocols listed in Table 3.1, the data frame size is also shown.

The important factors for consideration when assessing communication protocols for smart metering are summarized in Table 3.2

Protocol	Local AMR	Remote AMR	Smart metering	HAN	Estimated frame size (bytes)
PCT/IR		Y	Y	Y	50
IEC 62056	Y	Y	Y	Y	14
SML	Y	Y	Y	Y	14
IEC 61334 PLC		Y	Y		45
EN 13757 M-Bus	Y	Y	Y	Y	27
SITRED	Y	Y	Y		45
PRIME	Y	Y	Y		8
Zigbee Smart Energy			Y	Y	25
Ever Blu	Y	Y	Y	Y	
OPERA/UPA		Y	Y		24
IEC 62056-21 'FLAG'	Y	Y			22
IEC 62056-21 'Euridis'	Y	Y			45
ANSI C12.22		Y	Y		64

Table 3.1

Criteria	Description
Openness	Availability of protocol specifications. Status of controlling body
Interoperability	Extent of ability to interact with other standards, applications and protocols
Scalability/Adaptability	Ease with which the protocol can be extended or changed.
Intended function	The intended function of the smart meter such as communicating data to a central entry for billing or communicating data to a third party for other market operations.
Maturity	The stage at which the protocol is in its development
Performance	The speed and efficiency with which the protocols operate
Security	Existence of known security vulnerabilities

Fig 3.2

DEMAND SIDE INTEGRATION

Demand-Side Integration (DSI) is a set of measures to use loads and local generation to support network operation/management and improve the quality of power supply. DSI can help defer investment in new infrastructure by reducing system peak demand. In practice, the potential of DSI depends on: availability and timing of information provided to consumers, the duration and timing of their demand response, performance of the ICT infrastructure, metering, automation of end-use equipment and pricing/contracts.

There are various terms in use in the demand side, whose meanings are closely related to each other but with slightly different focuses. Some widely used definitions are:

- i) *Demand-Side Management (DSM)*: utility activities that influence customer use of electricity. This encompasses the planning, implementation and monitoring of activities designed to encourage consumers to change their electricity usage patterns.
- ii) *Demand Response (DR)*: mechanisms to manage the demand in response to supply conditions.
- iii) *Demand-Side Participation*: a set of strategies used in a competitive electricity market by end-use customers to contribute to economic, system security and environmental benefits. DSI covers all activities focused on advanced end-use efficiency and effective electricity utilisation, including demand response and energy efficiency

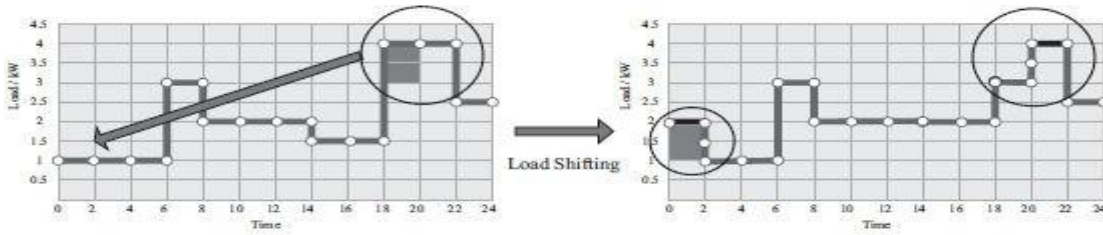

Figure 5.13 Load shifting

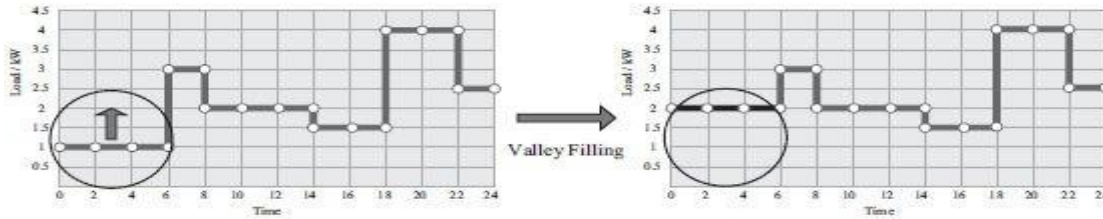

Figure 5.14 Valley filling

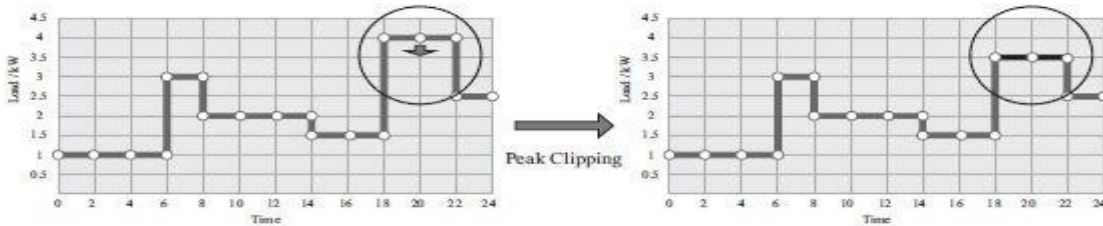

Figure 5.15 Peak clipping

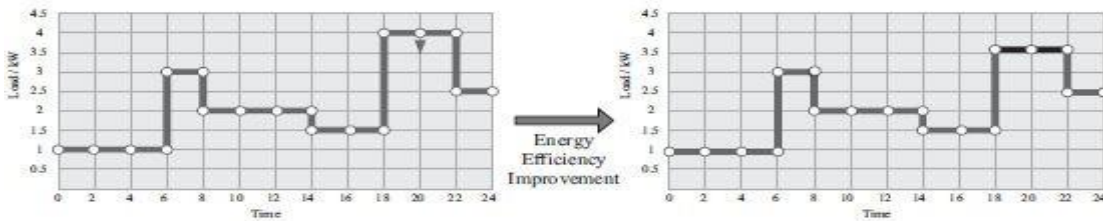

Figure 5.16 Energy efficiency improvement

Services provided by DSI

Demand-side resources such as flexible loads, distributed generation and storage can provide various services to the power system by modifying the load consumption patterns. Such services can include load shifting, valley filling, peak clipping, dynamic energy management, energy efficiency improvement and strategic load growth. Simple daily domestic load profiles are used to illustrate the function of each service, as shown in Figures.

Load shifting is the movement of load between times of day (from on-peak to off-peak)

or seasons. In Figure 5.13, a load such as a wet appliance (washing machine) that consumes 1 kW for 2 hours is shifted to off-peak time.

Figure 5.14 shows the main purpose of valley filling, which is to increase off-peak demand through storing energy, for example, in a battery of a plug-in electric vehicle or thermal storage in an electric storage heater. The main difference between valley filling and load shifting is that valley filling introduces new loads to off-peak time periods, but load shifting only shifts loads so the total energy consumption is unchanged (as shown in Figure 5.13).

Peak clipping reduces the peak load demand, especially when demand approaches the thermal limits of feeders/transformers, or the supply limits of the whole system. Peak clipping (Figure 5.15) is primarily done through direct load control of domestic appliances, for example, reducing thermostat setting of space heaters or control of electric water heaters or air-conditioning units. As peak clipping reduces the energy consumed by certain loads (in Figure 5.15, 2 kWh of energy is reduced), often consumers have to reduce their comfort.

Energy efficiency programs are intended to reduce the overall use of energy. Approaches include offering incentives to adopt energy-efficient appliances, lighting, and other end-uses; or strategies that encourage more efficient electricity use, for example, the feedback of consumption and cost data to consumers, can lead to a reduction in total energy consumption. Figure 5.16 shows the reduction in energy demand when ten 60 W filament lamps (operating from 18.00 hrs to 22.00 hrs) are replaced by 20 W Compact fluorescent lamps.

POWER QUALITY MANAGEMENT

Power Quality Management address events like Voltage flickering (Sags/Swells), unbalanced phases voltages and harmonic distorted/contaminated supply etc. This will facilitate efficient and reliable operation of the power system, reduce losses, improve customer satisfaction and reduced equipment (utility/consumer) failures. Power Quality management shall include voltage / VAR Control, Load balancing, Harmonics Controller etc.

Power Quality is a set of electrical boundaries that allows a equipment to function in its intended manner without significant loss of performance or life expectancy. Faults, dynamic operations, nonlinear loads, increased use of sensitive electronic circuitry by industrial and residential customer, long length & heavily loaded distribution lines ,embedded generation cause various types of power quality disturbances such as voltage sags, voltage swells, switching

transients, impulses, notches, flickers, harmonics, etc. Power Quality Management aimed at detecting and analyzing as well as minimizing the effects of power quality disturbances on industrial and customer loads.

Low voltage & low power factor causes higher losses, overheating, reduced life of appliances / equipment and higher O & M costs. Capacitor bank & statcom helps in controlling voltage & power factor in the system by automatically or manually providing reactive power compensation.

Harmonics in power system are signals having frequency integer multiples of power frequency (50 Hz), which causes higher losses in the power system, failure of equipment / appliances and conductor overheating. Deployment of closed loop active filters which use principle of frequency-domain filtering approach are the solution to remove harmonics apart from basic methodology of using line reactors/chokes/isolation transformers.

Voltage unbalance is handled by shunt connected thyristor-controlled static VAR compensator and changing the system configuration through manual and automatic feeder switching.

Flicker is defined as 'Impression of unsteadiness of visual sensation induced by a light stimulus whose luminance or spectral distribution fluctuates with time. It can be eliminated by proper designing the power system to handle load variations, using rapid response voltage regulators (static VAR compensators) or fast-response reactive compensation using inverter reactive- power capabilities.

SCADA

In a distribution/ transmission system, when equipment are large in number and scattered over a huge area, it becomes difficult for simultaneous monitoring of these equipment manually. This necessitates the use of SCADA system. SCADA encompass the transfer of data between a SCADA central host computer and a number of Remote Terminal Units (RTUs) and/or Programmable Logic Controllers, and the operator terminals. A SCADA system gathers information (such as voltage, current, CB status, operation of relay during fault, etc.), transfers the information to central host computer, that fault has occurred, carry out control and necessary action, and display the information in a logical and organized fashion.

SCADA systems consist of:

- One or more field data interface devices, usually RTUs, which interface to field sensing devices and local control switchboxes. RTU transfers data to control centre on standard Modbus, DNP3 or 60870-5-101/103/104 protocols.
- A communication system used to transfer data between field data interface devices and control units and the computers in the SCADA central host. The communication system can be PLC, telephone cable, optic fiber, satellite, etc., or any combination of these.
- A central host computer server or servers (sometimes called a SCADA Center, master station, or Master Terminal Unit (MTU))
- A collection of standard and/or custom software [sometimes called Human Machine Interface (HMI) software or Man Machine Interface (MMI) software] systems used to provide the SCADA central host and operator terminal application, support the communications system, and monitor and control remotely located field data interface devices.

A systematic diagram of SCADA Architecture is given below in Figure

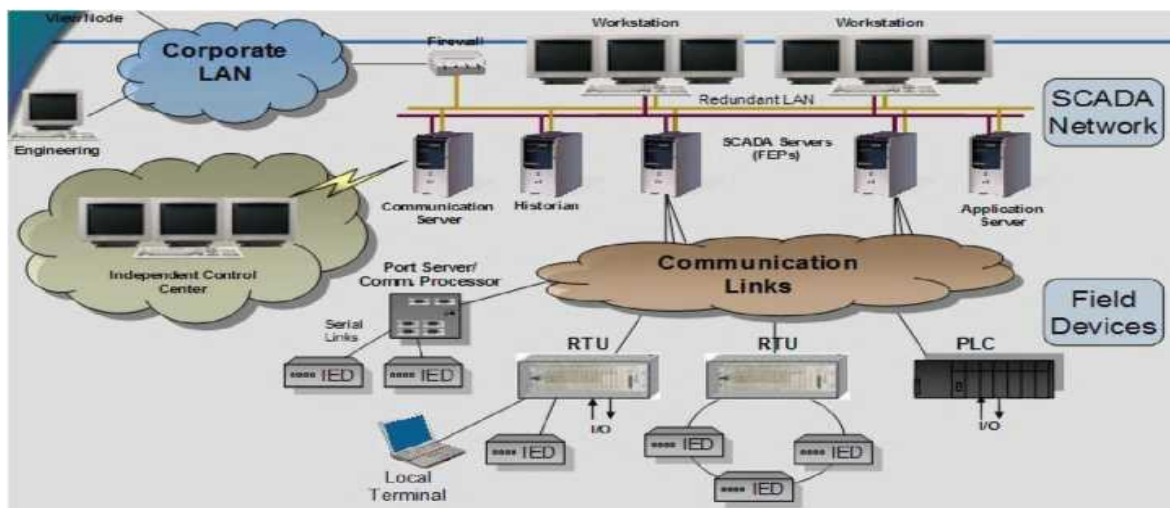

Following functions are performed by SCADA system:

- Data acquisition- provides telemetered measurements and status information to operator.
- Supervisory Control- allows operator to remotely control devices e.g. open and close of circuit breakers
- Data Processing-This includes alarms which informs operator of un-planned events and undesirable operating conditions, Sequence of Event (SoE) recording and generalized calculations.
- Disturbance data collection-This includes collection of outage data from relays & as well as fault reports/ summaries etc.
- Historical information storage & retrieval-Stores data for analyzing purpose as well as it also provides data for displaying past trends for better planning in future.

OUTAGE MANAGEMENT SYSTEMS

Outage Management System is a system which is more advanced with respect to Automated Distribution System, OMS will have higher level of intelligence & data as it is integrated with other systems such as Advanced Metering Infrastructure (AMI) for proper functioning as compare to automated distribution system which only gets data from SCADA, while OMS also uses sophisticated fault locating & monitoring equipment for fast action.

Outage Management System is basically a system comprising of some fault locating equipment & computer based tools to do following activities efficiently & effectively:

- i. Locating & Diagnosing of fault
- ii. Dispatching of Crew members
- iii. Feedback to consumers
- iv. Restoration of fault
- V. Maintaining of historical records
- vi. Calculation of reliability indices (SAIFI)

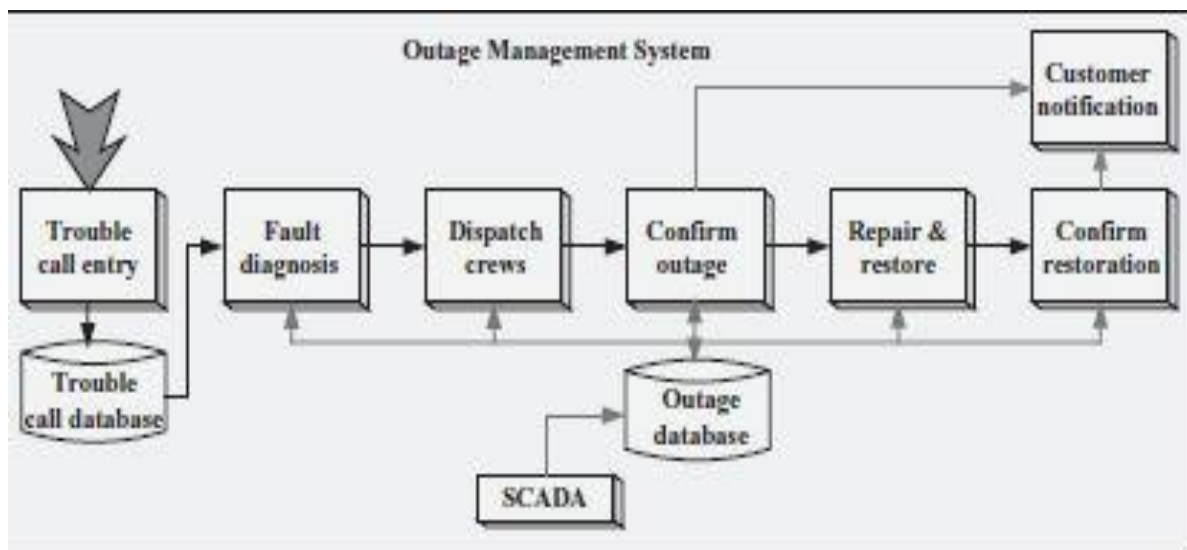

This gives high level of consumer satisfaction and most efficient outage management. The schematic of Outage Management System is shown in Figure.

Outage Management System is integrated with different systems such as;

- GIS mapping, which covers consumer indexing & asset mapping of complete area to be locate on satellite map.
- Field equipment like Fault passage indicators (FPI) which communicate faulty section location to control centre and helps in reduction of outage duration as patrolling for fault finding would be required for detected section only.
- Distribution Transformer Monitoring Units(DTMU) which monitor oil temperature, oil level & LT side load current / parameters, harmonics& energy values of the distribution transformers, which avoid failure of transformer due to overloading or low oil level.
- Interface with RTUs/ Communication Gateways installed in each substation to collect the data, for real time monitoring.
- Interface with Advanced Metering Infrastructure for loss of power & reconfiguration of feeder
- Integration with Interactive Voice Response (IVR) system for interaction with consumers.
- Integration with Crew Management System to dispatch nearest & skillful crew members to fault location

Equipment's used in Outage Management system are as below:

RTU/Feeder RTU (FRTU):

RTU / FRTUs communicate switches status & electrical parameters like voltage, current etc. from different feeder points / DT/ RMU at field locations to control centre. These RTUs / FRTUs receive command from control centre for operation of switches at site to achieve faster restoration / isolation.

Distribution Transformer Monitoring Units (TMUs):

The DTMUs monitor oil levels, oil temperatures, loading conditions and internal fault in distribution transformers. This will also help in taking proactive actions for maintenance of Distribution Transformer.

Fault Passage Indicators (FPI):

Fault Passage Indicators identifies location / type of faults through visual indications at control centre. The Identification of section under fault is used to direct maintenance crew for quick recovery of faulty section for subsequent restoration of faulty part.

Outage management systems manage outages by way of manual intervention, self-healing and maintenance crew management. Continuous monitoring of the system helps in proactive & preventive maintenance, which in turn reduce outages frequency and duration. Whenever a fault take place following information shall reach control centre:

- a) Location of fault through FPI.FPI in faulty section will operate due to high fault conditions.
- b) De-Energisation status of the consumers shall be communicated by smart meters installed under advanced metering infrastructure to the Meter data management system, which will share the information of such consumer with outage management system
- c) The information of CB or Auto Reclosures (AR) switches of faulty section shall be sent via RTU / communication gateway to control centre SCADA system from where same shall be shared with outage management system.
- d) Customer complaints for non-receipt of power shall be logged on customer care centre, which would obtain information about customer with GIS mapping interface and would further communicate the information to outage management system.

SMART HOME ENERGY MANAGEMENT SYSTEM

Under the Smart Grid regime, to bring efficiency and reap the maximum benefit of Smart Grid implementation "Smart Home Energy Management System" would play a key role at the end user level. The Smart Home Energy Management System will enable the end user to monitor energy consumption & cost of electricity, optimize energy usage, control appliances and other devices, make informed decisions under variable pricing structure, participate in demand response programs empowering consumer involvement in energy management process. It will also enable the users to keep their energy bills low by efficiently monitoring and controlling the appliances in the home remotely or automatically. This capability will require new access to data from the electric supplier (marginal price, current consumption, load curtailment signals) as well as interactive capabilities between consumer and home appliances to permit override of planned / automated actions.



Fig Smart Home

Smart Home Energy Management System would also need establishment of Home area networks (HANs) through which utilities can communicate to individual consumer in support of demand management applications. It is the interface to communicate with the electric utility. The electric meter is considered the obvious choice for the communications interface to the residential consumer. Various components of Smart Home Energy Management Systems are: Controlled devices, various loads, Communication Gateways, Monitoring Devices, Remote / Automatic (Programmable) Controller.

i) Energy Efficiency

Energy Efficiency has assumed great importance in view of the need to conserve depleting energy resources as well as to minimize the carbon footprint of the power sector. One research by McKinsey on Sustainability & Resource Productivity indicates that if select existing technologies were to be fully deployed by 2020, a new home could consume about 90 per cent less energy, whether gas or electricity, from the grid than it does today.

Reduction of 33 units by: Central systems and smart applications Electric heat pump, nanotechnologies and smart applications (eg, membrane in air- conditioning ,unit), energy-efficient lighting, home control network.

Reduction of 28 units by: Building fabrics

Insulation of roof and walls with aerogel, hollow bricks, active windows, double-shell building

Reduction of 7 units by: Appliances and electronics

Includes appliances and electronics with most advanced potential for reducing energy consumption: advanced washing machines, refrigerators, and freezers; energy-efficient televisions; and other electronics.

Reduction of 20 units by Distributed generation Solar-photovoltaic systems, mini-

combined heat and power, micro wind

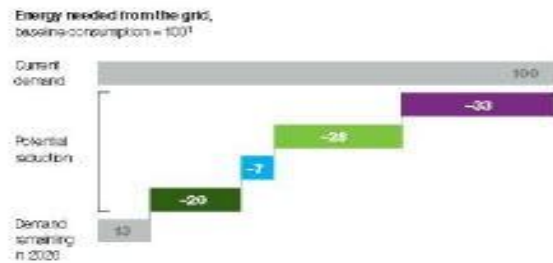

For existing homes, which form the majority of housing stock, the energy-savings opportunity is also substantial: cuts of 35 to 40 % could be achieved. Use of energy efficient appliances like TV, FAN, Lighting, AC, Solar Water Heater, etc. can significantly reduce the household energy demand, bringing efficiency into the system and saving in consumer electricity bill. (Refer Table)

Average Power Saving through Energy Efficiency per House hold		
	Summer	Winter
Peak Demand Reduction (watt)	1217	2485
Reduction in Monthly Consumption (kWh)	266	199
Value of Saving per House hold		
Average Tariff	RS. 4.00 / Unit	
Monthly Saving	Rs. 1,063	Rs. 796
Annual Saving (Winter 4 months & Summer 8 Months)	Rs. 11,688	
Annual Air pollution reduction(tonnes of CO ₂)	2.60	

Say, if a consumer has to invest an additional amount of Rs. 35,000/- to achieve such saving, it can be easily recovered within 3 years without compromising on comfort. Such saving has the potential of reducing the peak demand of a city with 1 crore household by 12000 MW and reduction in annual energy consumption by 30 billion units. This will help in deferring the infrastructure investment of about Rs. 1 Lakh Crore by utilities. Environment will also be benefitted by reduction in CO₂, by these energy efficient measures.

UNIT-IV

UNIT IV: INFORMATION AND COMMUNICATION TECHNOLOGY

Overview of smart grid communication system– Modulation and Demodulation techniques- Radiocommunication–Mobile communication–Power line communication– Optical fibre communication –Communication protocol for smart grid

OVERVIEW OF SMART GRID COMMUNICATION SYSTEM

Data communication systems are essential in any modern power system and their importance will only increase as the Smart Grid develops. Successful implementation of smart grid depends extremely on the reliable communications between a broad set of geographically distributed elements, including hardware, sensors and control devices that enable to integrate and interface with control & automation of distribution infrastructure. The **Figure** below gives a brief overview of Smart Grid Communication system in power system distribution system

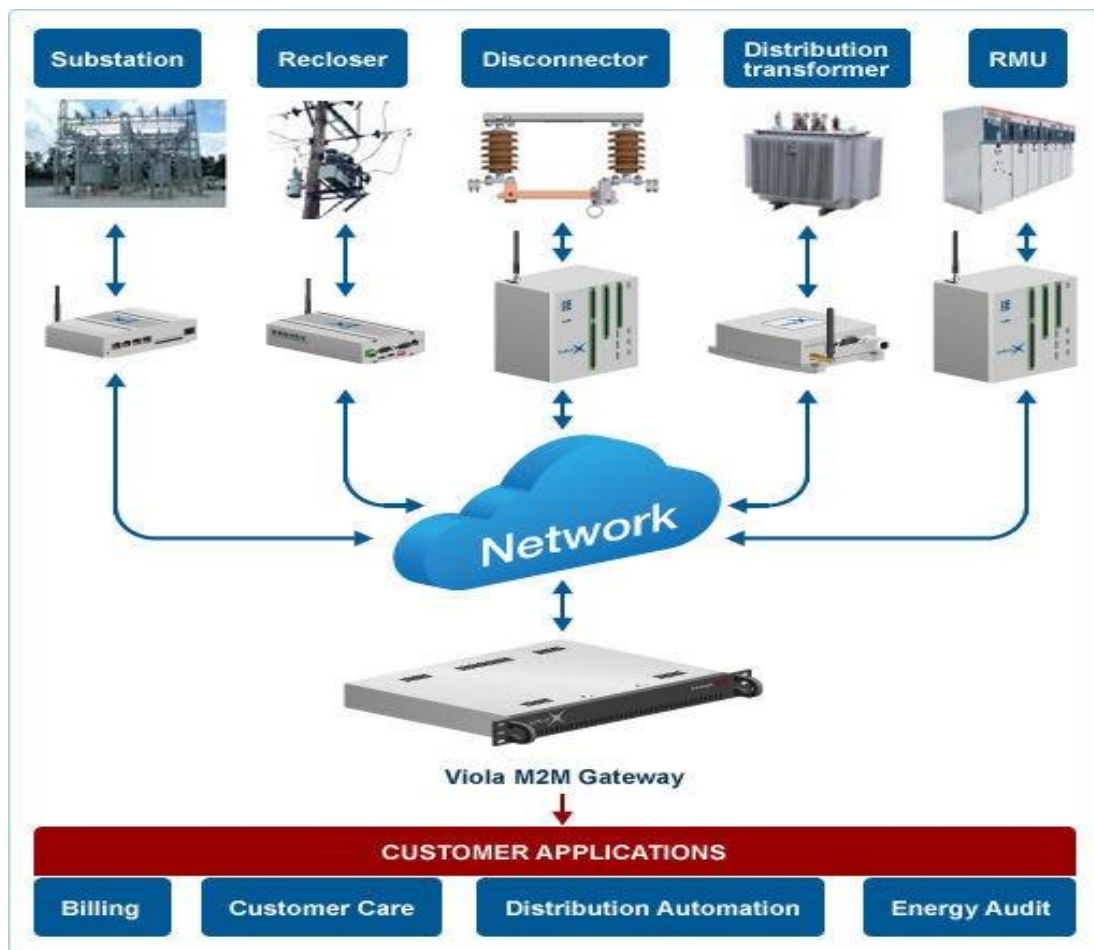

Figure 1: Overview of Smart Grid Communication System

2.2 Dedicated and shared communication channels

Certain applications require the transmission of data from one point to another and other uses may require the transmission of data from one point to multiple points. When a secure communication channel is required from one point to another, a dedicated link is used exclusively by the Source and Destination only for their communication. In contrast, when a shared communication channel is used, a message sent by the Source is received by all the devices connected to the shared channel. An address field within the message specifies for whom it is intended. Others simply ignore the message.

Figure 2.2 shows a typical communication network used inside a substation. Each bay has a controller which takes the local measurements (e.g. from current and voltage transformers) and contains the software required for protection and control of the bay primary equipment (e.g. transformers and circuit breakers). These bay controllers are connected to substation control and monitoring equipment (station computer, RTUs) through a star or ring connection as shown in Figures 2.2a and 2.2b. In the star connection (Figure 2.2a), each bay controller has a dedicated link to the station computer. In the ring connection (Figure 2.2b), the bay controllers and the station computer are connected through a shared medium to form a Local Area Network (LAN).

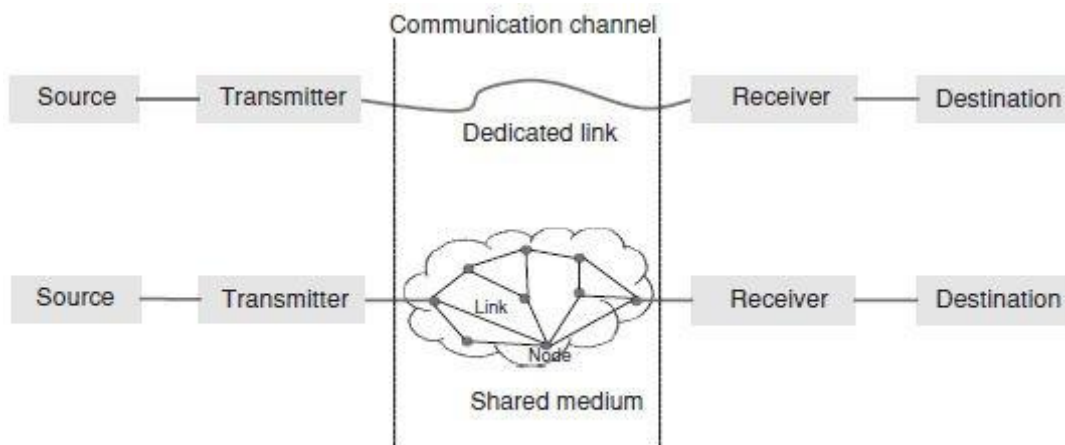

Figure 2.1 Model of simple point-to-point communication system

Dedicated communication channels are used for differential protection of transmission lines. The communication channel is used to transmit a signal corresponding to the summation of the three line currents (they are added using a summation transformer) at one relaying point to another for comparison with similar signal at that point (see Figure 2.3).

In the differential protection scheme of Figure 2.3, a pilot wire communication or power line carrier may be used. A bit stream from the differential IED is first modulated with a carrier.

Table 2.1 Examples of the physical devices in a power system communication system

Component	Physical device
Source	Voltage transformer Current transformer
Transmitter	Remote terminal unit (RTU)
Communication channel	LAN (Ethernet)
Receiver	Network interface card
Destination	Work station with graphic display IED for protection and control

Table 2.2 Power system applications and the communication requirements from [1]

Application	Response time required (including latency)	Network topology and communication technology
Protection of transmission circuits	< 20 ms	Dedicated point-to-point links
Protection of distribution circuits	< 100 ms	Circuit switching and packet switching

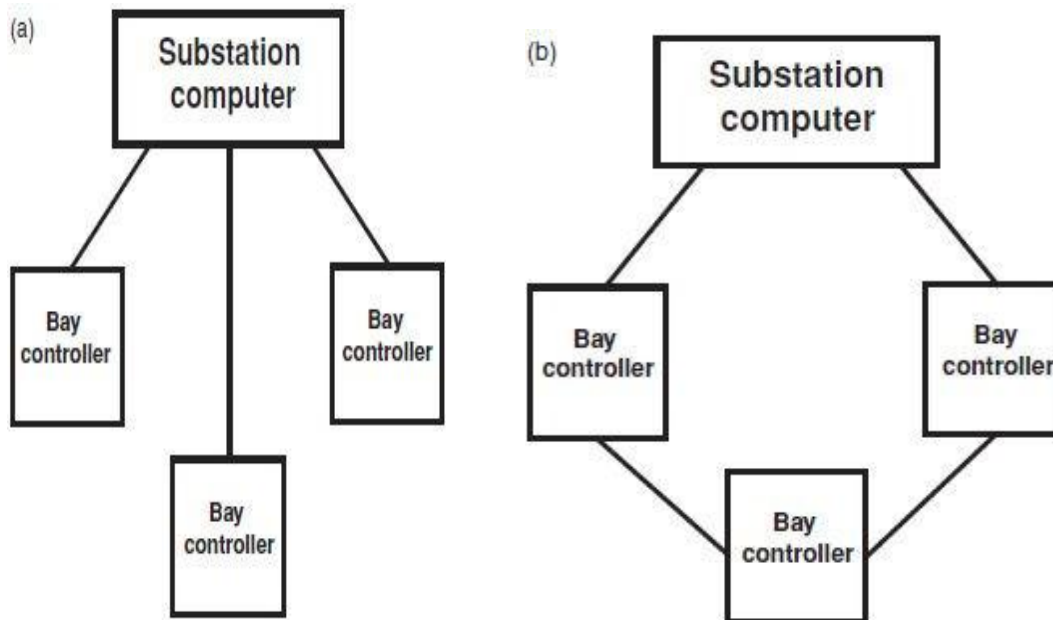

Figure 2.2 Communication within the substation [2]. (a) star connection, (b) ring connection

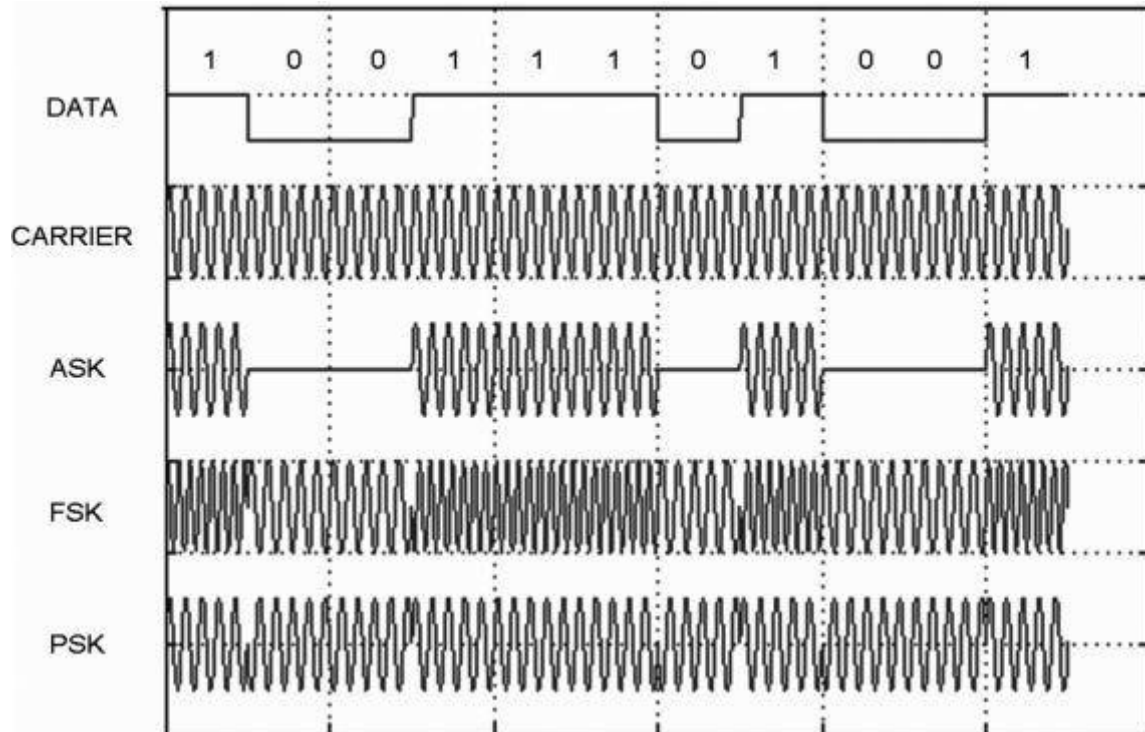

Figure 2.4 Modulation of carrier signals by digital bit streams

The modulation techniques usually employed are: Amplitude Shift Keying (ASK), Frequency Shift Keying (FSK) and Phase Shift Keying (PSK) . In ASK, the carrier frequency remains constant and the digital information is encoded in changes to carrier amplitude, as shown in Figure 2.4. In both FSK and PSK, the carrier amplitude remains constant with changes in the carrier frequency, or the phase of the carrier signal being used to modulate the digital information.

Figure 2.5 shows a shared communication channel inside a substation that uses a multi-drop connection arrangement. The substation computer sends messages addressed to one or more IEDs; each IED takes its turn to communicate with the substation computer to avoid conflicts that could arise due to simultaneous access to the shared medium.

In Figure 2.5, analogue measurements from the CT are first digitized using an encoder (situated inside the IED). The simplest and most widely used method of digitizing is Pulse Code Modulation (PCM) where the analogue signal is sampled at regular intervals to produce a series of pulses. These pulses are then quantized by assigning a discrete value as shown in Figure 2.6. This discrete value is then converted to a binary number that results in a bit stream which is subjected to further encoding depending upon the transmission medium used.

Bits may be transmitted either asynchronously, that is, start and stop bits at the beginning and end of a block of data are used to identify the bits in the block, or synchronously, where the sender and receiver maintain the same speed for sending and receiving data using a clock signal. An example of asynchronous communication is the EIA 232 standard¹ which is widely used to connect terminal equipment to computers over short distances. Figure 2.6

SWITCHING TECHNIQUES

Switching techniques are used to establish a link between a Source and a Destination and to transmit data across a shared medium communication channel. This is often a network consisting of nodes and links as shown in Figure 2.1. A node could be a network adaptor, a Switch, or a Router. A node performs such tasks as routing data or acting as a gateway between Figure 2.6two different types of network. Hosts, connected to nodes, are able to exchange information between them through the communication network. This configuration is cost-effective and scalable as the number of Hosts grows and geographical coverage expands. Circuit switching, message switching and packet switching are commonly used switching techniques for data transfer between Source and Destination.

1 Circuit switching

In circuit switching, a dedicated physical connection is set up for the exclusive use of Source and Destination during the communication session. Nodes and links allocated for a communication session cannot be used by any Source/Destination other than the two involved in the communication session. This makes circuit switching inefficient if the data transmission pattern is intermittent.

2 Message switching

In message switching, the Source sends a message to a node. A message could be measurement data collected by a sensor or a control function. The node stores the data in its buffer. When the entire message has been delivered to the node, it then looks for a free link to another node and then sends the data to this node. This process continues until the data is delivered to the Destination. Owing to its working principle, it is also known as store and forward.

3 Packet switching

Packet switching dominates in today's data communication networks for reasons of economy and reliability. A message is transmitted after breaking it into suitably sized blocks, called packets. When traversing network adapters, Switches, Routers and other network nodes, packets are buffered and queued, resulting in variable delay and throughput depending on the traffic load in the network.

There are two approaches to packet switching; virtual circuit packet switching and datagram packet switching.

1 Virtual circuit packet switching

Figure 2.7 shows the packet flow patterns of a typical virtual circuit packet switching node. Two Sources have been identified as A and B. Packets corresponding to each Source are identified by the Source identification letter followed by a numerical figure. The lower the numerical figure, the earlier the packet is transmitted by the Source. For instance, packet A1 is transmitted before packet A2.

Prior to data transfer, a path from Source to Destination is established. Data transfer takes place after establishing the connection and at the end of data transmission, the connection is released. Therefore the packets follow the same path from Source to Destination. One important feature of virtual circuit packet switching is that the order of packet delivery is preserved. In other words, packets transmitted from the Source will reach the Destination in the same order as they left the Source. The packets transmitted through several virtual circuits are multiplexed through physical links as shown in Figure 2.7. This allows efficient utilization of the capacity of a physical link.

Since the path from Source to Destination is set up at the beginning, the need to carry a complete Destination address in each packet is eliminated. This contributes to the reduction of the transmission overhead. Virtual circuit packet switching has the disadvantage that in the case of a node failure, there is complete loss of circuit and the path has to be re-established from the beginning.

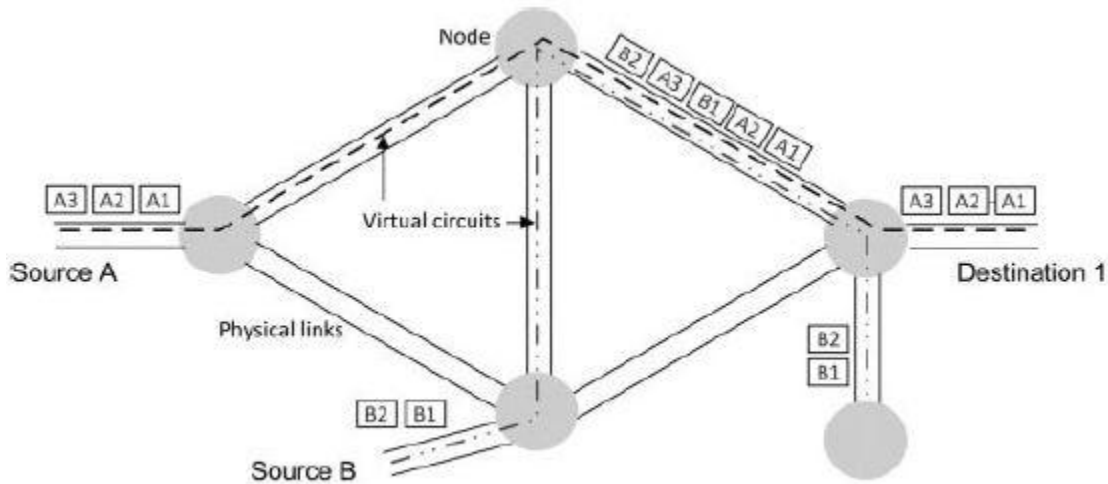

Figure 2.7 Virtual circuit packet switching

2 Datagram packet switching

In datagram packet switching, packets are handled independently (Figure 2.8). Therefore, each packet needs to carry a complete Destination address in it. There is no guarantee that packets belonging to one Source will follow the same path. Consequently, there is no guarantee that packets will arrive at the Destination in the order they were transmitted from the Source. The failure of a node during transmission only affects packets in that node and the communication session will not be disrupted as in the case of virtual circuit packet switching.

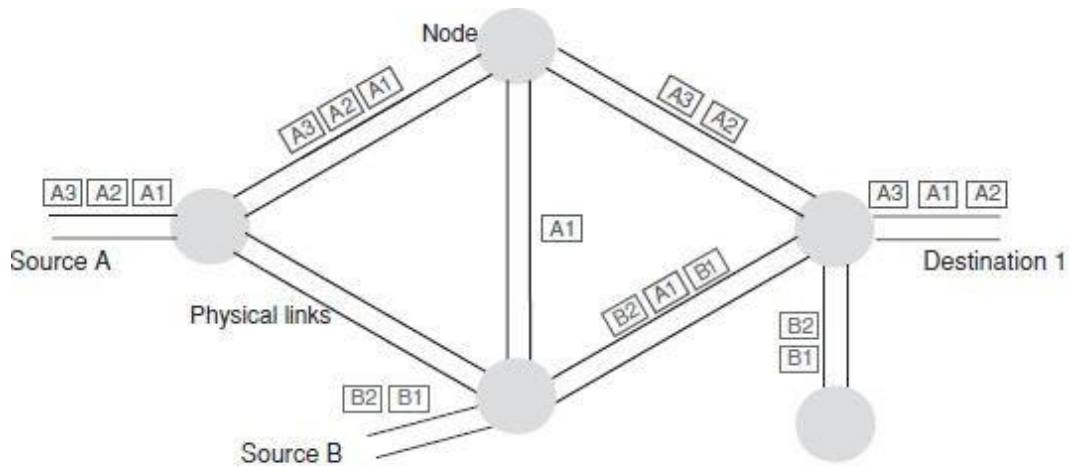

Figure 2.8 Datagram packet switching

2.4 Communication channels

Communication channels run through physical media between a Source and a Destination. In the case of dedicated channels, a single medium, as shown in Figure 2.9, is generally used. Shared communication channels may involve more than one medium, depending on the route the signal travels. A communication channel may be provided through guided media such as a copper cable or optical fibre or through an unguided medium such as a radio

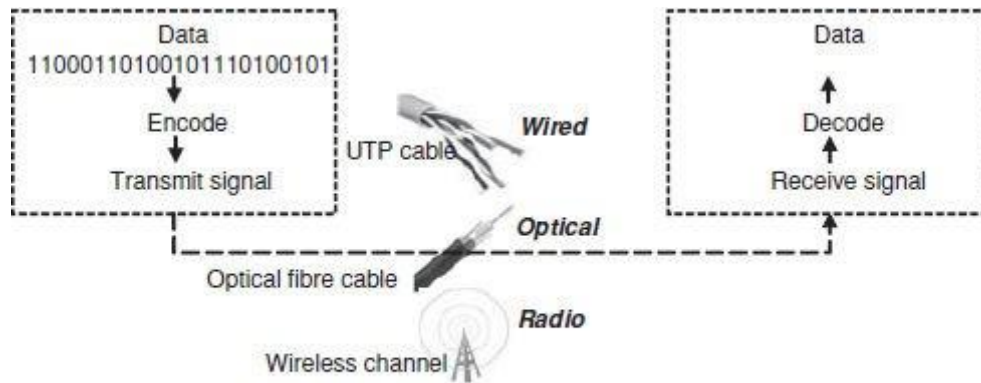

Figure 2.9 Example of data transmission media (wired, optical or radio)

link.

The performance of a communication channel is mainly described by the following parameters:

1. Bandwidth/Bit rate: Bandwidth is the difference between the upper and lower cut-off frequencies of a communication channel. In an analogue system it is typically measured in Hertz. In digital transmission the term bit rate is often used to express the capacity (some books refer to as bandwidth) of a channel. The bit rate is measured in bits per second (bps).

2. Attenuation: As a signal propagates along a communication channel, its amplitude decreases. In long-distance transmission, amplifiers (for analogue signals) and repeaters (for digital signals) are installed at regular intervals to boost attenuated signals. For example, when transmitting digital signals in copper cables, repeaters are required every 10 km, whereas optical fibre can take a signal without significant attenuation over a distance as great as 100 km.

3. Noise: In communication, electrical noise is an inherent problem. When digital signals are travelling inside the channel, sometimes noise is sufficient to change the voltage level corresponding to logic '0' to that of logic '1' or vice versa. Noise level is normally described by the Signal to Noise Ratio (SNR) and measured in decibels (dB). SNR is defined by:

$$\text{SNR} = 10 \log_{10} \left[\frac{\text{signal power}}{\text{noise power}} \right]$$

For example, if the SNR = 20 dB, from Equation (2.1), it may be seen that the ratio of signal power to noise power is $10(20/10) = 100$.

4. Signal propagation delay: The finite time delay that it takes for a signal to propagate from Source to Destination is known as propagation delay. In a communication channel both the media and repeaters (see Chapter 3) that are used to amplify and reconstruct the incoming signals cause delays. As some of the Smart Grid applications require real-time low latency communication capabilities, it is important to consider the propagation delay of a channel.

RADIO COMMUNICATION

The substations of power networks are often widely distributed and far from the control centre. For such long distances, the use of copper wire or fibre optics is costly. Radio links provide an alternative for communication between the Control Centre and substations. Even though radio communication cannot provide the bandwidth offered by wired technology, the reliability, performance and running costs of radio networks have improved considerably over the past few years, making it an attractive option.

Radio communication may be multipoint or point-to-point, operating typically either at UHF frequencies (between 300 MHz and 3 GHz) or microwave frequencies (between 3 and 30 GHz).

1. Ultra high frequency

UHF radio represents an attractive choice for applications where the required bandwidth is relatively low and where the communication end-points are widespread over harsh terrain. It uses frequencies between 300 MHz and 3 GHz. Unlike microwave radio, UHF does not require a line of sight between the Source and Destination. The maximum distance between the Source and Destination depends on the size of the antennae and is likely to be about 10–30 km with a bandwidth up to 192 kbps.

2. Microwave radio

Microwave radio operates at frequencies above 3 GHz, offering high channel capacities and transmission data rates. Microwave radio is commonly used in long-distance communication systems. Parabolic antennas are mounted on masts and towers at the Source to send a beam to another antenna situated at the Destination, tens of kilometres away. Microwave radio offers capacity ranging from a few Mbps to hundreds of Mbps. However, the capacity of transmission

over a microwave radio is proportional to the frequency used, thus, the higher the frequency, the bigger the transmission capacity but the shorter the transmission distance. Microwave radio requires a line of sight between the Source and Destination, hence, high masts are required. In case of long-distance communications, the installation of tall radio masts will be the major cost of microwave radio.

ZigBee - For RF mesh networks

ZigBee is a specification for communication protocols used to create personal area networks built from small, low-power digital radios in 2.4 GHz to 2.4835 GHz frequency ranges. Zigbee is based on an IEEE 802.15 standard. Though low-powered, ZigBee devices often transmit data over longer distances by passing data through intermediate devices to reach more distant ones, creating a mesh network. This standard specifies operation in the unlicensed 2.4 GHz bands. Sixteen channels are allocated in the 2.4 GHz band, with each channel requiring 5 MHz of bandwidth. The radios use direct-sequence spread spectrum coding, which is managed by the digital stream into the modulator. Wireless mesh networks are effective systems for the deployment of reliable large scale Advanced Metering Infrastructure (AMI) networks and are widely implemented.

Advantage of ZigBee

The low cost of Zigbee allows the technology to be widely deployed in wireless control and monitoring applications. Low power-usage allows longer life with smaller batteries. It uses the IEEE 802.15.4 PHY standard but has the freedom to define proprietary Media Access Control (MAC) and network protocols. Mesh networking provides high reliability and more extensive range. In AMI implementation, RF Zigbee (2.4 - 2.4835 GHz) is suitable for consumers where two consumers are in close proximity of around 20-30 meters. ZigBEE protocol is interoperable.

Disadvantage of ZigBee

Low processing capabilities, small memory size and small delay requirements are subjected to interference with other industrial appliances. The obstacle between two meters should be minimum. Meters should not be installed in metal enclosure.

Sub-GHz Frequency band

The license free band i.e. 865 -867 MHz is called Sub-GHz band. IEEE 802.15.4g protocol can be implemented in this band. However, most of the companies are using their proprietary protocol. Binary phase-shift keying (BPSK) is used in the 868 MHz bands.

Home Area Network (HAN) consists of RF transceivers which forms a mesh network controlled either by Smart meter or Home Gateway. HAN use License free RF bands to communicate among each other. ZigBee is a low-cost, low-power, wireless mesh network standard used for communication with meter/ home gateway and HAN.

Sub-GHz band (865-867 MHz) provides following benefits over 2.4 GHz un-licensed band:

- Less Interference: Most of the equipment viz WiFi, Bluetooth, toys etc. work at 2.4 GHz frequency and causing interference.
- Increased range with less attenuation: Radio waves at lesser frequency have better range and can easily bend round obstacles, can reflect with least attenuation from dense objects such as metallic walls or vessels.
- Mesh networking reliability: Due to better range, mesh networking formed on 865 MHz has better reliability.

General Packet Radio Service (GPRS)

GPRS stands for the General Packet Radio Service. It is a packet-based wireless communications service, based on GSM (which is circuit based) communication, and is recognized in the business as the best platform for mobile data networking services.

GPRS is an upgrade or a smooth add-on to integrate into existing networks and can be thought of as an overlay network onto a second-generation GSM network. GPRS integrates GSM and IP technologies to provide wireless data services and it offers instant data connections to data networks, such as the Internet, ISP's and corporate Intranets.

GPRS is a technology that is used globally. It is not restricted location wise really, in the sense that it can reach anywhere that current GSM networks can reach. The ordinary person can use it on their mobile phones to access e-mail and the internet, and businesses can use it to access the office server of for M2M deployments.

GPRS Networks

For the core GSM network to handle packet traffic two new components, called GPRS Support Nodes, are added:

- Serving GPRS Support Node (SGSN)
- Gateway GPRS Support Node (GGSN)

The SGSN is a network element that converts protocols between the IP core and the radio network (it assigns IP addresses). It also performs mobility management functions and location management (it tracks the movement of the user to know where to send packets). It also ensures a secure connection. The GGSN connects the GPRS network to the Internet, ISP's and corporate Intranets, it acts like a gateway to the other networks. It also performs address mapping.

Devices supporting GPRS are divided into three classes:

- Class A devices which can be connected to GPRS service and GSM service (voice, SMS), using both at the same time. Such devices are known to be available today.
- Class B devices which can be connected to GPRS service and GSM service (voice, SMS), but using only one or the other at a given time. During GSM service (voice call or SMS), GPRS service is suspended, and then resumed automatically after the GSM service (voice call or SMS) has concluded. Most GPRS mobile devices are Class B.

- Class C devices are connected to either GPRS service or GSM service (voice, SMS). Such devices must be switched manually between services.

GPRS connectivity used for AMI applications requires recurring cost to service provider and expensive when millions of meters are involved and coverage in of GPRS in non-urban areas is still poor. Moreover reliability of this medium under the given the network congestion and call drops is questionable. In case of service level agreement with service provider for defined reliability, it is very costly.

The data from DCUs and GPRS based Smart meters reaches GPRS service provider's server via mobile access network. Service provider's server pushes data from through a virtual private network created over internet to utility server (MDAS). Generally all this systems for fetching data over internet and making them accessible to customer is done with the help of web services.

Third Generation (3G) mobile communication technology And General Packet Radio Service 3G, short for third Generation, is the third generation of mobile telecommunications technology that provide an information transfer rate of at least 200 kbit/s. The communication spectrum between 400 MHz to 3 GHz was allocated for 3G.

General packet radio service (GPRS) is a packet oriented mobile data service on the 2G and 3G cellular communication system's global system for mobile communications (GSM). GPRS was originally standardized by European Telecommunications Standards Institute (ETSI). In 2G systems, GPRS provides data rates of 56-114 kbit/second.

MOBILE COMMUNICATIONS

Mobile communication systems were designed initially to carry voice only. The standard that has enabled this technology is GSM (Global System for Mobile Communications). As an add-on data service to GSM technology, the General Packet Radio Service (GPRS) was developed. GPRS uses the existing GSM network and adds two new packet-switching network elements: the GGSN (Gateway GPRS Support Node) and the SGSN (Serving GPRS Support Node). In December 1998, the European Telecommunications Standards Institute, the Association of Radio Industries and Businesses/Telecommunication Technology Committee of Japan, the China Communications Standards Association, the Alliance for Telecommunications Industry Solutions (North America) and the Telecommunications Technology Association (South Korea) launched a project called the 3rd Generation Partnership Project (3GPP). The aim of the 3GPP project was to develop a 3rd Generation mobile systems (3G) based on GSM, GPRS and EDGE (Enhanced Data Rates for GSM Evolution). The project was built on data communication rather than voice. This project rapidly evolved to provide many different technologies as shown in Figure 3.20. The data rates of the different technologies that evolved under 3GPP are shown in Table 3.6.

LTE is a competing technology to WiMax and supports user mobility up to 350 km/h, coverage up to 100 km, channel bandwidth up to 100 MHz with spectral efficiency of the Downlink 30 bps/Hz and the Uplink 15 bps/Hz. LTE has the advantage that it can support seamless connection to existing networks, such as GSM and UMTS as shown in Figure 3.21.

Table 3.6 Peak data rates of the 3GPP family

Technology	Peak data rates (Mbps)	
	Uplink	Downlink
GSM/EDGE	0.5	1.6
HSDPA and HSUPA	5.76	14.4
HSPA	22	56
LTE	75	300
LTE-Advanced	500	1000

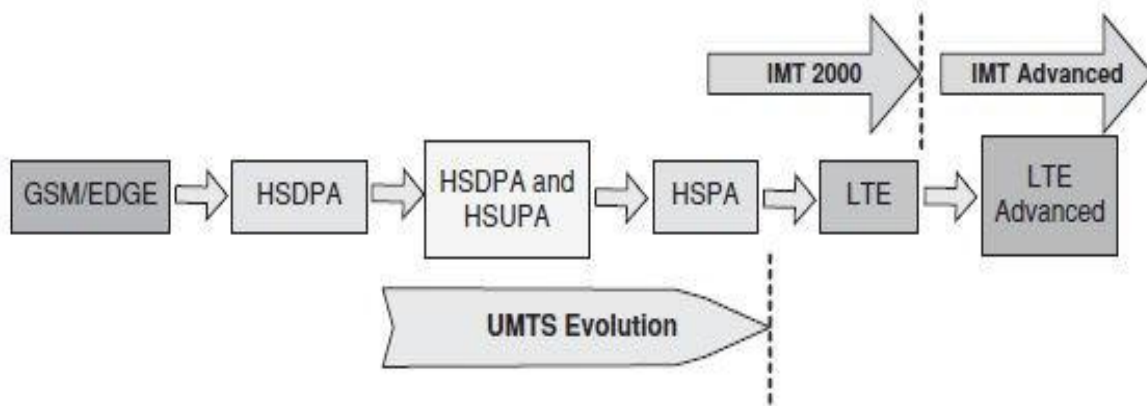

EDGE: Enhanced Data Rates for GSM Evolution

GSM: Global System for Mobile Communications

HSDPA: High Speed Downlink Packet Access

HSUPA: High Speed Uplink Packet Access

HSPA: High Speed Packet Access

IMT: International Mobile Telecommunication s

UM TS: Universal Mobile Telecommunication System

Figure 3.20 Evolution of the 3GPP family

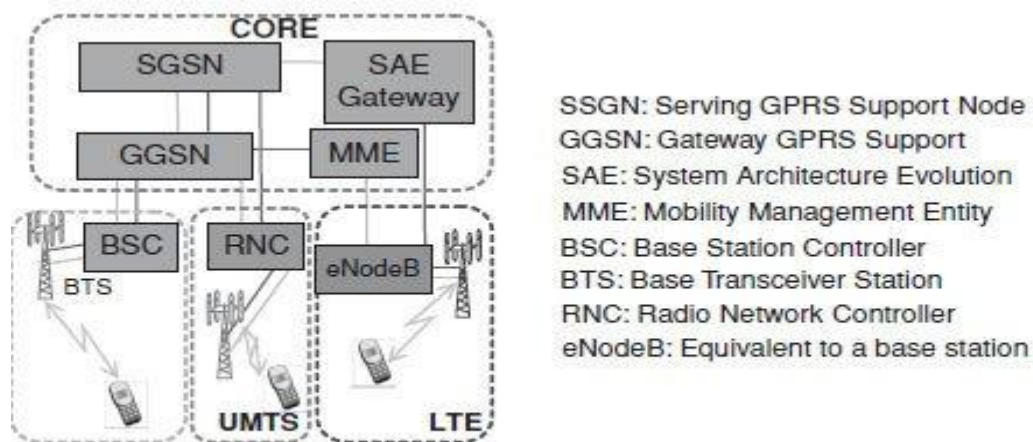

Figure 3.21 LTE connecting to legacy networks

CELLULAR MOBILE COMMUNICATION

Cellular mobile technology offers communication between moving objects. To make this possible, a service area is divided into small regions called cells. Each cell contains an antenna which is controlled by a Mobile Telephone Switching Office (MTSO) as shown in Figure 2.16.

In a cellular network, the MTSO ensures the continuation of communication when a mobile device moves from one cell to another. For example, assume that a mobile user in cell *A* communicates through the antenna located in the base station of cell *A*. If the user moves out of range of cell *A* and into the range of cell *B*, the MTSO automatically assigns a communication channel in cell *B* to the user without interrupting the communication session.

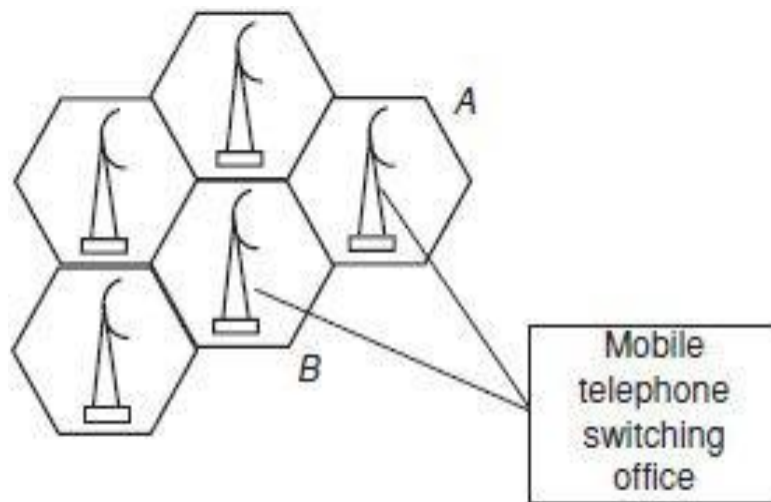

Figure 2.16 A cellular system

SATELLITE COMMUNICATION

Satellites have been used for many years for telecommunication networks and have also been adopted for Supervisory Control And Data Acquisition (SCADA) systems. A satellite communication network can be considered as a microwave network with a satellite acting as a repeater.

1. Geostationary orbit satellite communication

Currently, many satellites that are in operation are placed in Geostationary Orbit (GEO). A GEO satellite or GEOS is typically at 35,786 km above the equator and its revolution around the Earth is synchronised with the Earth's rotation. The high altitude of a GEO satellite allows communications from it to cover approximately one-third of the Earth's surface. Even though GEO satellite-based communication offers technical advantages in long distance communication, it still presents some drawbacks. They include:

1. The challenge of transmitting and detecting the signal over the long distance between the satellite and the user.

2. The large distance travelled by the signal from the Source to reach the Destination results in an end-to-end delay or propagation delay of about 250 ms.

2. Low earth orbiting (LEO) satellite communication

LEO satellites are positioned 200–3000 km above the Earth, which reduces the propagation delay considerably. In addition to the low delay, the proximity of the satellite to the Earth makes the signal easily detectable even in bad weather. LEO satellite-based communication technology offers a set of intrinsic advantages such as: rapid connection for packet data, asynchronous dial-up data availability, reliable network services, and relatively reduced overall infrastructure support requirements when compared to GEO. In addition, LEO satellite-based communication channels can support protocols such as TCP/IP since they support packet-oriented communication with relatively low latency.

POWER LINE COMMUNICATION

Power Line Communication is a communication technology that enables transferring data over AC power wiring. So there is no need to any additional wiring for communication network. Communication is achieved by adding a high frequency signal at low energy levels over the electric signal and the second signal is propagated through the power network to the receiving end. Electrical devices can be easily interconnected and managed through power lines. Power line communication (PLC) carries data on a conductor that is also used simultaneously for AC electric power transmission or electric power distribution to consumers. Power line communication (PLC) leverages the existing power line infrastructure and provides cost-effective approach for introducing intelligent monitoring and control to many industrial applications. It makes PLC one of the leading enabling technologies for Smart Grid applications ranging from smart metering, lighting control, solar, plug-in electrical vehicle home and building automation of heat and air conditioning, and security.

The principle of PLC is that a high frequency information signal is added ('modulated') to the 50Hz power flow signal ('carrier signal') at the sending end and is removed at the receiving end('de-modulated'), as shown in the following diagram:

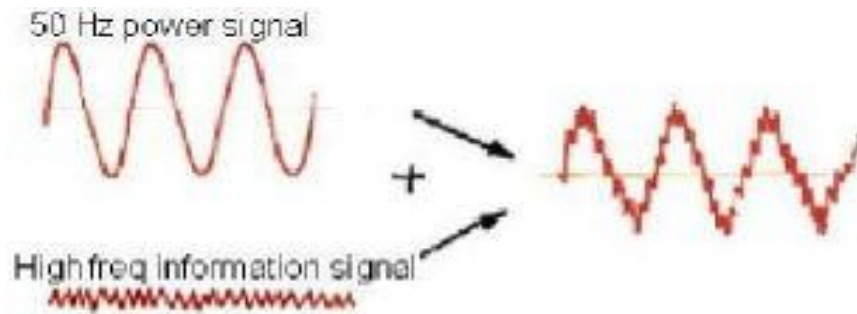

PLC is appealing because there is no need to run additional wires to powered devices. PLC can also work where radio frequency (RF) cannot. For example smart meters in the basement of a building basement are unlikely to be able to use RF to communicate with the neighborhood data concentrator. PLC communication on the other hand can traverse the power wires to reach the data concentrator. There are three primary challenges to reliable communications: high attenuation on the power line, the presence of noise sources on the power line, and channel distortion.

There are two main modulation technologies for PLC- Spread Frequency Shift Keying (SFSK) and Orthogonal Frequency Division Multiplexing (OFDM), of which OFDM based ones are the latest. The most widespread PLC techniques on the market is spread frequency shift keying (S-FSK). S-FSK also known as IEC 61334 is a standard for low-speed reliable power line communications.

Even though by using PLC we are taking advantage of the existing power line infrastructure one should keep in mind that communication quality can be affected by varying power line impedances, load, and electromagnetic interferences. Typically data signals cannot propagate through transformers and hence the power line communication is limited within each line segment between transformers. Data rates on power lines vary from a few hundred of bits per second to millions of bits per second, in a reverse proportional relation to the power line distance.

Power line communication is appealing because it uses the existing power line infrastructure. The basic block diagram of QPSK based on network for proposed Smart Micro-Grid is shown in Fig.3. Data server was developed to allow multiple PLC connections to smart grid and flexible control over the message exchange between users and smart micro-grid.

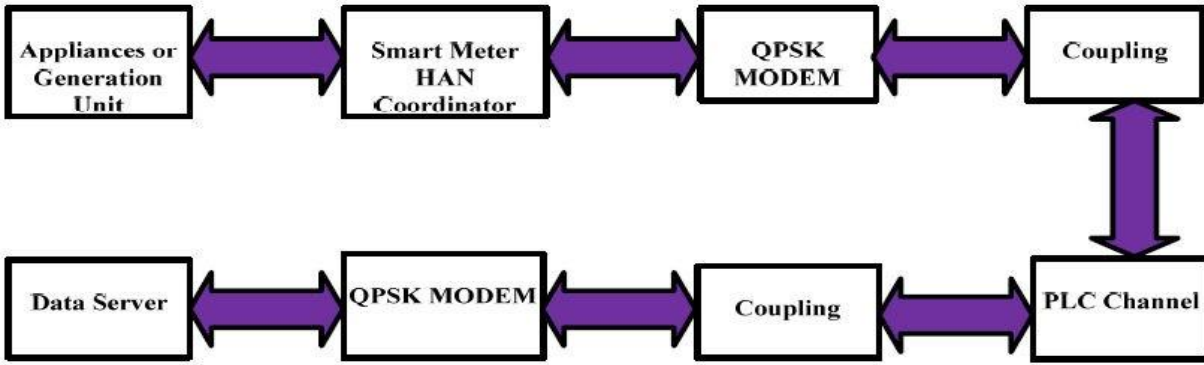

Fig.3. Block Diagram of QPSK Based on PLC Network For Smart Micro-Grid

The smart is a digitally-enhanced version of the traditional grid, where deployed advance communication technologies and computing technologies. In Fig.3, coordinator of HAN device is connected with home appliance and smart meter. Smart meter is connected with Smart micro-grid by QPSK based PLC Modem and coupling circuit. The control unit manages HAN network configuration, as well as exchanges information between each home appliances and PLC network. In this gateway, power utility company is able to be connected to not only smart meter but also to the existing electric appliances in home via PLC network . Technologies are now widely available that bi-directional communication for PLC network. So PLC network is well-suited to rural areas and cost effective solution to communicate between power utility companies and its customers where there is no other communication networks exist.

i) IEEE P1901

Under the sponsorship of the IEEE Communication Society, the IEEE P1901 working group was formed in 2005 with the remit to develop a standard for high speed (> 100 Mbps at the physical layer) communication devices via electric power lines, the so-called Broadband over Power Line (BPL) devices.

ii) HomePlug

HomePlug is a non-standardized broadband technology specified by the HomePlug Powerline Alliance, whose members are major companies in communication equipment manufacturing and in the power industry.

Home Plug Power line Alliance defines the following standards:

1. Home Plug 1.0: connects devices in homes (1–10 Mbps).
2. Home Plug AV and AV2: transmits HDTV and VoIP in the home – 200 Mbps (AV) and 600 Mbps (AV2)

OPTICAL FIBRE COMMUNICATION

Optical fibre transmission is used both inside substations and for long-distance transmission of data. Optical fibres are often embedded in the stranded conductors of the shield (ground) wires of overhead lines. These cables are known as Optical Ground Wires (OPGW). As shown in Figure 2.12a, an OPGW cable contains a tubular structure with one or more optical fibres in it, surrounded by layers of steel and aluminium wire. Optical fibres may be wrapped around the phase conductors or sometimes a standalone cable, an all-dielectric self-supporting (ADSS) cable, is used. As shown in Figure 2.12b, an optical fibre consists of three components: core, cladding and buffer. The thin glass centre of the fibre where the light travels is called the core. The outer optical material surrounding the core that reflects the light back into the core is called the cladding. In order to protect the optical surface from moisture and damage, it is coated with a layer of buffer coating.

Compared to other communication media, fibre optic cables have a much greater bandwidth. They are less susceptible to signal degradation than copper wire and their weight is less than a copper cable. Unlike electrical signals in copper wires, light signals from one fibre do not interfere with those of other fibres in the same cable. Further, optical fibre transmission is immune to external electromagnetic interference (EMI). This is important in power system applications since data transmission through the electrically hostile area of a substation is required.

The main disadvantages of optical fibre transmission include the cost, the special termination requirements and its vulnerability (it is more fragile than coaxial cable).

Figure 2.13 shows the path of a light signal travelling inside an optical fibre. A light signal from the optical source is first incident on surface A and then refracted inside the core. The signal is then incident on the surface between the core and cladding. The subsequent path depends on the incident angle, θ_1 [6].

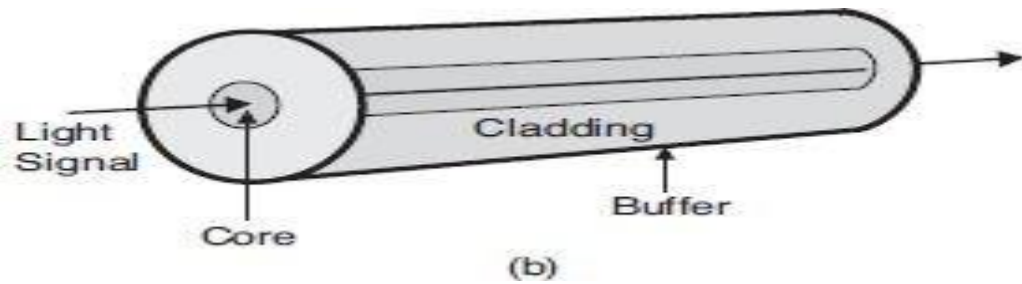
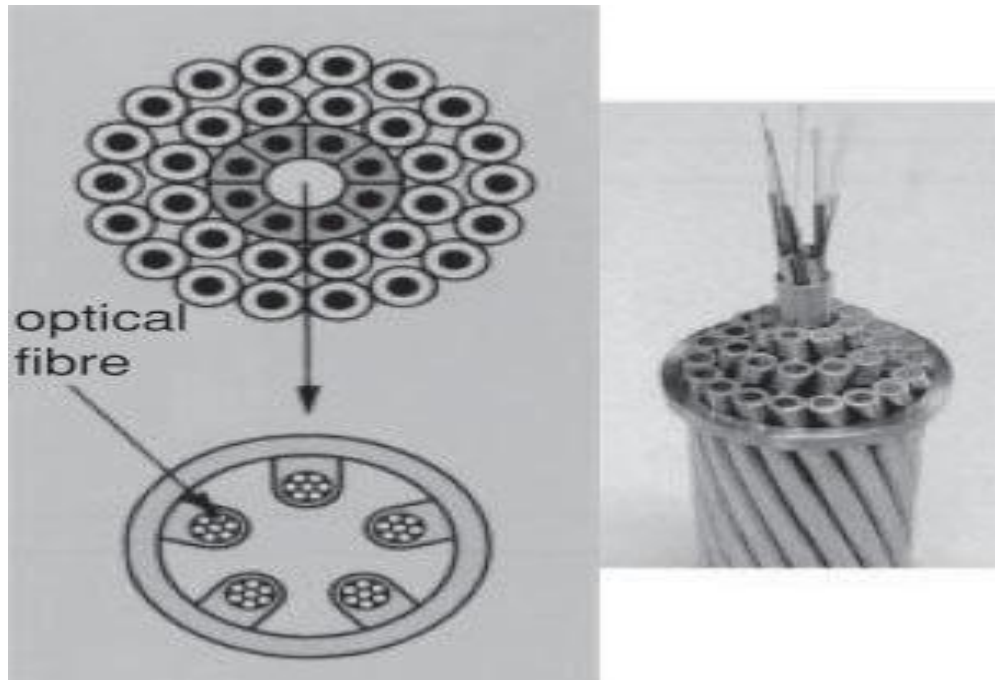

Figure 2.12 Optical fibres. Source: OPGW cable picture, courtesy of TEPCO, Japan

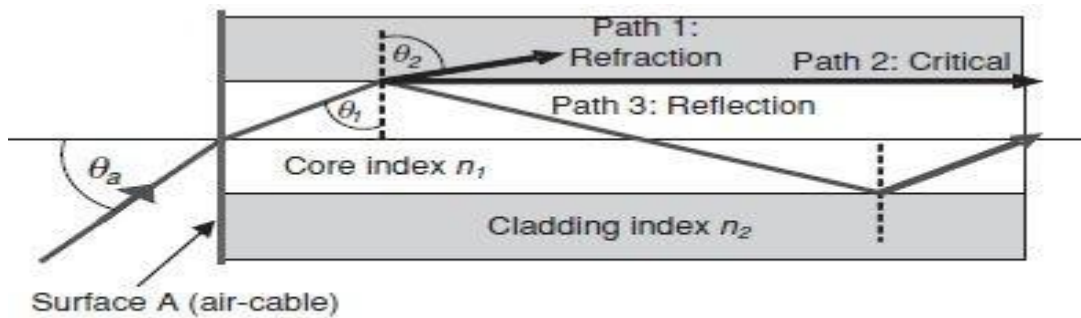

Figure 2.13 Principle of fibre optics

By applying the law of refraction at surface A, the following equation can be obtained:

$$n_0 \sin \theta_a = n_1 \sin \left(\frac{\pi}{2} - \theta_1 \right) = n_1 \cos \theta_1 \quad (2.2)$$

where θ_a is the angle of acceptance n_1 , n_2 and n_0 are the refractive indices of core, cladding and air.

Since, for the free space $n_0 = 1$, from Equation (2.2):

$$\sin \theta_a = n_1 \cos \theta_1 \quad (2.3)$$

At the core-cladding surface:

- If the light signal takes path 1 $n_1 \sin \theta_1 = n_2 \sin \theta_2$ and the signal will not be received at the Destination.
- For critical reflection (path 2), $n_1 \sin \theta_1 = n_2 \sin \pi/2 = n_2$.
- Path 3 shows reflection (essential to guide a signal along the core of an optical fibre cable

from Source to Destination):

$$n_1 \sin \theta_1 > n_2 \quad (2.4)$$

From Equation (2.4):

$$1 - \cos^2 \theta_1 > \left(\frac{n_2}{n_1}\right)^2 \quad (2.5)$$

By substituting for $\cos \theta_1$ from Equation (2.3), the following equation is obtained from Equation (2.5):

$$\left(\frac{\sin \theta_a}{n_1}\right)^2 + \left(\frac{n_2}{n_1}\right)^2 < 1$$

$$\therefore \theta_a < \sin^{-1} (n_1^2 - n_2^2)^{1/2}$$

$\sin \theta_a = (n_1^2 - n_2^2)^{1/2}$ is referred to as the numerical aperture of the optical fibre.

Depending on the core diameter, there may be multiple transmission paths or a single transmission path within the core of a fibre. Optical fibre cables having core diameters of 50–400 μm reflect light entering the core from different angles, establish multiple paths (as shown in Figures 2.14a and b) and are called multimode fibres. On the other hand, fibre with a much smaller core diameter, 5–10 μm , supports a single transmission path. This is called single mode fibre (Figure 2.14c). Single mode fibres have advantages such as low dispersion, low noise, and can carry signals at much higher speeds than multimode fibres. Therefore, they are preferred for long-distance applications.

Commonly used multimode fibres are:

1. *Step index fibre*: This cable has a specific index of refraction for the core and the cladding. It is the cheapest type of cable. Its large core diameter allows efficient coupling to incoherent

light sources such as Light Emitting Diodes (LED). Different rays emitted by the light source travel along paths of different lengths as shown in Figure 2.14a. As the light travels in different paths, it appears at the output end at different times.

2. *Graded index fibre*: In graded index fibre, rays of light follow sinusoidal paths as shown in Figure 2.14b. Although the paths are different lengths, all the light reaches the end of the fibre at the same time.

PERFORMANCE OF COMMUNICATION CHANNELS

A communication channel may be provided through guided media such as a copper cable or optical fibre or through an unguided medium such as radio link. The performance of a communication channel is mainly described by the following parameters:

- i. **Bandwidth / Bit rate**: Bandwidth is the difference between the upper and lower cut-off frequencies of a communication channel. In an analogue system it is typically measured in Hz. In digital transmission the term bit rate is often used to express the capacity (also known as Bandwidth) of a channel. The bit rate is measured in bits per second (bps).
- ii. **Attenuation**: As a signal propagates along a communication channel, its amplitude decreases. In long-distance transmission, amplifiers (for analogue signals) and repeaters (in digital signals) are installed at regular intervals to boost attenuated signals. For example, when transmitting digital signals in copper cables, repeaters are required every 10 km whereas optical fibre can take a signal without significant attenuation over a distance as great as 100 km
- iii. **Noise**: In communication, electric noise is an inherent problem. When the digital signal are traveling inside the channel, sometimes noise is sufficient to change the voltage level corresponding to logic '0' to that of logic T or vice versa. Noise level is normally described by the Signal to Noise ratio (SNR) and measured in decibels (dB). SNR is defined by:

$$\text{SNR} = 10 \log_{10}(\text{signal power} / \text{noise power})$$

For example, if the SNR is 20 dB, from the equation it may be seen that the ratio of signalpower to noise power is $10^{(20/10)} = 100$.

iv. **Signal Processing Delay:** The finite time delay that it takes for a signal to propagate from Source to destination is known as propagation delay. In a communication channel both the media and repeaters that are used to amplify and reconstruct the incoming signals cause delays.

TCP/IP

The **Transmission Control Protocol (TCP)/Internet Protocol (IP) or TCP/IP** is the most widely used protocol architecture today. It is a result of a project called Advanced Research Projects Agency Network (ARPANET) funded by the Defense Advanced Research Project Agency (DARPA) in the early 1970s. The TCP/IP protocol architecture used in the Internet evolved out of ARPANET.

Five layers, as shown in Figure 2.21, are defined in the TCP/IP architecture. They are: Physical layer, Network access layer, Internet layer, Transport layer and Application layer .

The role of the Physical layer of the TCP/IP is identical to that of the Physical layer in the ISO/OSI reference model. It deals with the specifications of electrical and mechanical aspects of interfaces and transmission media. It is also responsible for encoding data into signals, defining data rate and the synchronization of bits.

The Network layer is responsible for providing an error-free channel for the Internet layer. Its functions include: encapsulation of IP packets coming from the Internet layer into frames, frame synchronization, error detection and correction, logical link control, providing flow and error control, media access control, physical addressing (MAC addressing), LAN switching, data packet queuing or scheduling algorithms, and IP address to/from physical address resolution.

The main responsibility of the Internet layer is routing packets from Source to Destination. Identifying Hosts uniquely and universally is essential for routing packets as datagrams across networks. The Internet layer uses an identifier called the IP address to identify devices connected to a network. There are two versions, IPv4 and IPv6, of IP addressing currently in use. IP version 4 (IPv4) is still the most commonly used. Since its introduction in 1998 with the publication of IETF RFC2373 [12] and RFC2460 , IP version 6 is becoming more widely used in the internet.

The Transport layer is represented by the Transmission Control Protocol (TCP). TCP creates a virtual circuit between the Source to Destination and is responsible for sending all datagrams generated by the Source. TCP establishes a transmission by informing the Destination that there are more data to be transmitted and terminates the connection only when all the datagrams have been transmitted.

The Application layer in TCP/IP is a combination of session, presentation and Application layers of the OSI model. Some of the protocols associated with the Application layer of TCP/IP are: Domain Name Server (DNS), File Transfer Protocol (FTP), electronic mail protocols such as Simple Mail Transfer Protocol (SMTP), Hypertext Transfer Protocol (HTTP) and Uniform Resource Locator (URL). More information about these is found in.

The Transmission Control Protocol (TCP) / Internet Protocol (IP) is the most widely used protocol architecture today. Five layers are defined in the TCP/IP architecture. They are Physical layer, Network access layer, Internet layer, Transport layer and application layer. The Internet layer uses an identifier called the IP address to identify devices connected to a network. These are two versions, IPv4 and IPv6, of IP addressing currently in use. IP version 4 (IPv4) is still the most commonly used.

IP version 4 (IPv4)

IPv4 addressing has two architectures called Classful and classless addressing. Classful addressing is the concept used initially and is still in use widely. Classless addressing was introduced in the mid-1990s and is expected to supersede classful addressing:

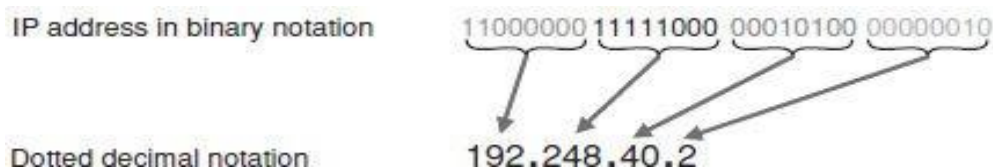

Fig: IP Version 4 Notation

1. Classful addressing:

In classful addressing, the 32-bit address space is divided into five classes called A, B, C, D and E. They are defined according to the bit pattern of the most significant octet as shown in Figure 2.23. The IPv4 classful addressing scheme recognizes the class of a network by looking at the first byte (octet) of the address as shown in Figure 2.23. The 32-bit address of a Host has two

parts, namely Network ID and Host ID. Network ID is common for all Hosts in a given network and Host ID is used to identify Hosts uniquely.

Network ID is used to transport data across networks and Host ID is used to deliver data to a particular Host within a network. As shown in Figure 2.23, the Class A network can theoretically have 224 (16,777,216) Hosts since it uses 24 bits to represent the Host ID. Likewise, the Class B and C networks can theoretically have 216 (65,536) and 28 (256) Hosts. In Class D a datagram is directed to multiple uses. Classful addressing could lead to a waste of IP addresses. For instance, not many organizations will be able to use Class A address space completely.

2. Classless addressing:

Classless addressing allows variable length blocks to assign only the required number of IP addressed to an organisation. Slash notation, which indicates the number of bits used for Network ID of the address, is used to identify network address as shown below:

(a) 192.248.40.0/24 – Only the first three bytes as shown under Class C in Figure 2.23 are used for Network ID. Here slash 24 stands for three bytes ($3 \times 8 = 24$ bits)

(b) 192.248.40.252/30 – The first three bytes and six leading bits from the fourth byte are used for Network ID. Here slash 30 stands for the first three bytes plus six bits from the last byte ($3 \times 8 + 6 = 30$ bits).

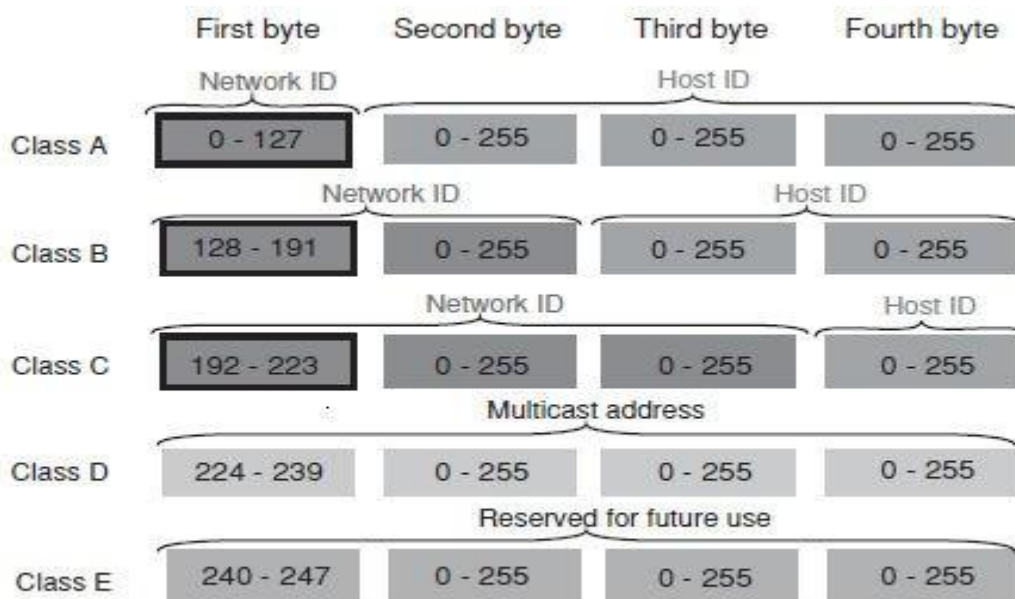

Figure 2.23 IPv4 classful addressing

IP version 6(IPv6)

IP version 6, also known as **IP Next Generation (IPng)** is a 128 bit addressing scheme and supports a virtually unlimited number of devices - 2 to the 128th power. Therefore it provides a much bigger address space compared to that of IPv4. The **Internet Engineering Task Force (IETF)**, a standards body, created IPv6 as a replacement to IPv4 in 1998, when it became clear that the Internet would eventually run out of IPv4 addresses. IPv6's primary goal is to increase the Internet's address space, but the protocol also has some enhancements, including auto configuration, easier network renumbering and built-in security through the IPsec protocol. The main advantages provided by IPv6 include:

1. Internet Protocol Security (IPsec) is mandatory for IPv6. It is a protocol suite for securing Internet Protocol (IP) communications by authenticating and encrypting each IP packet of a communication session.
2. Support for jumbograms which can be as large as 4,294,967,295 ($2^{32} - 1$) octets. In contrast, IPv4 supports datagrams upto 65,535 ($2^{16} - 1$) octets.

An IPv6 address is denoted using a format called hexadecimal colon notation as shown in Figure

Binary format(128 bits):

001000000000110011100100110110010000000000000000 0000000000000000
000000000000000011101000101100110000000000000001111110000010111

In Hexadecimal Colon Notation: 200C:E4D9:0000:0000:0000:E8B3:0000:FC17

Abbreviated address with consecutive zeros: 200C:0:0:0:E8B3:0:FC17

Abbreviated address with consecutive zero sections: 200C::E8B3:0:FC17

Figure 2.24 IPv6 address

PROTOCOL - DLMS / COSEM

Companion Specification for Energy Metering (COSEM), includes a set of specifications that defines the Transport and Application Layers of the DLMS protocol for data exchange with energy meters.

Device Language Message Specification (DLMS) is a generalized concept for abstract modeling of communication entities; basically it is a messaging method providing an interface between the COSEM objects and the communication protocols.

Application of DLMS/COSEM brings interoperability, means that any meter data management system can talk to any meter, independently of the manufacturer, the type, the energy type measured and the communication media.

Evaluation criteria for comparison of various communication systems

Communication systems form the back bone of smart grid system and play a vital role in the successful implementation of the Smart Grid. The reliability of communication system is a matter of critical importance as the same is an unavoidable essentiality in terms of proper working of the system. The main evaluation criteria for comparison of various communication systems are:

1. Reliability
2. Cost
3. Manageability
4. Accuracy
5. Security

The reliability of various communication media depends on the Geography, climate conditions, wiring condition, urban or rural. The reliability will vary area to area.

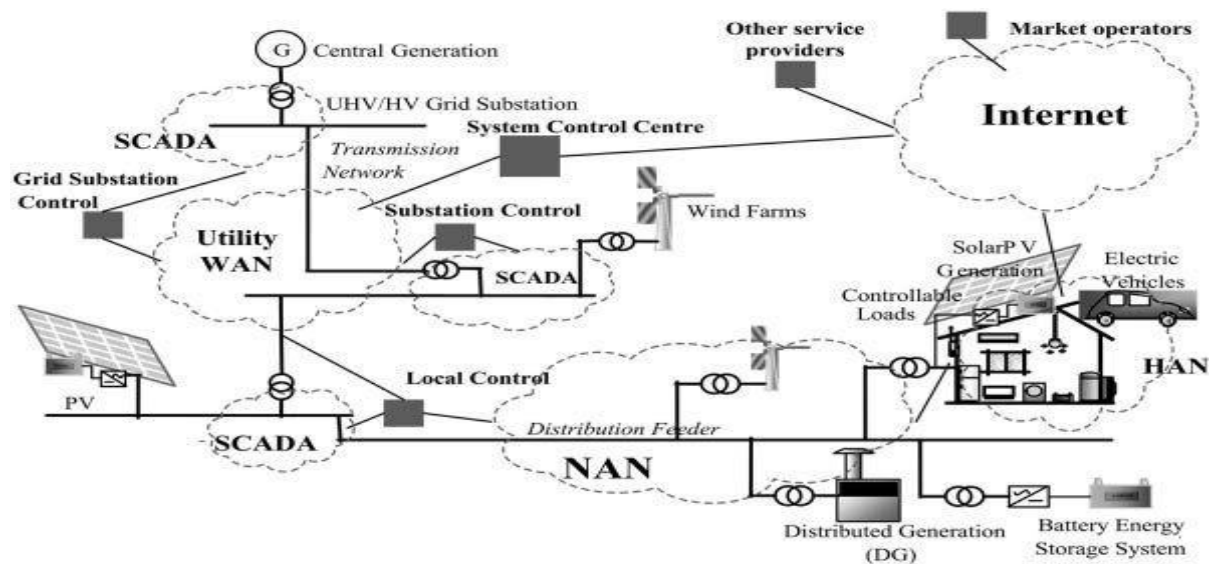

Figure 3.1 Possible communication infrastructure for the Smart Grid

UNIT V: SMART GRID APPLICATIONS

**Overview and concept of renewable integration – role of protective relaying in smart grid–
House Area Network– Advanced Energy Storage Technology - Flow battery– Fuel cell–
SMES–Super capacitors–Plug–in Hybrid electric Vehicles– Cyber Security requirements–
Smart grid information model**

OVERVIEW AND CONCEPT OF RENEWABLE ENERGY INTEGRATION

Renewable Energy Integration focuses on incorporating renewable energy, distributed generation, energy storage, thermally activated technologies, and demand response into the electric distribution and transmission system. A systems approach is being used to conduct integration development and demonstrations to address technical, economic, regulatory, and institutional barriers for using renewable and distributed systems. In addition to fully addressing operational issues, the integration also establishes viable business models for incorporating these technologies into capacity planning, grid operations, and demand-side management.

The goal of Renewable energy integration is to advance system design, planning, and operation of the electric grid to:

- Reduce carbon emissions and emissions of other air pollutants through increased use of renewable energy and other clean distributed generation.
- Increase asset use through integration of distributed systems and customer loads to reduce peak load and thus lower the costs of electricity.
- Support achievement of renewable portfolio standards for renewable energy and energy efficiency.
- Enhance reliability, security, and resiliency from Micro-grid applications in critical infrastructure protection and highly constrained areas of the electric grid.
- Support reductions in oil use by enabling Plug-In Electric Vehicle (PHEV) operations with the grid.

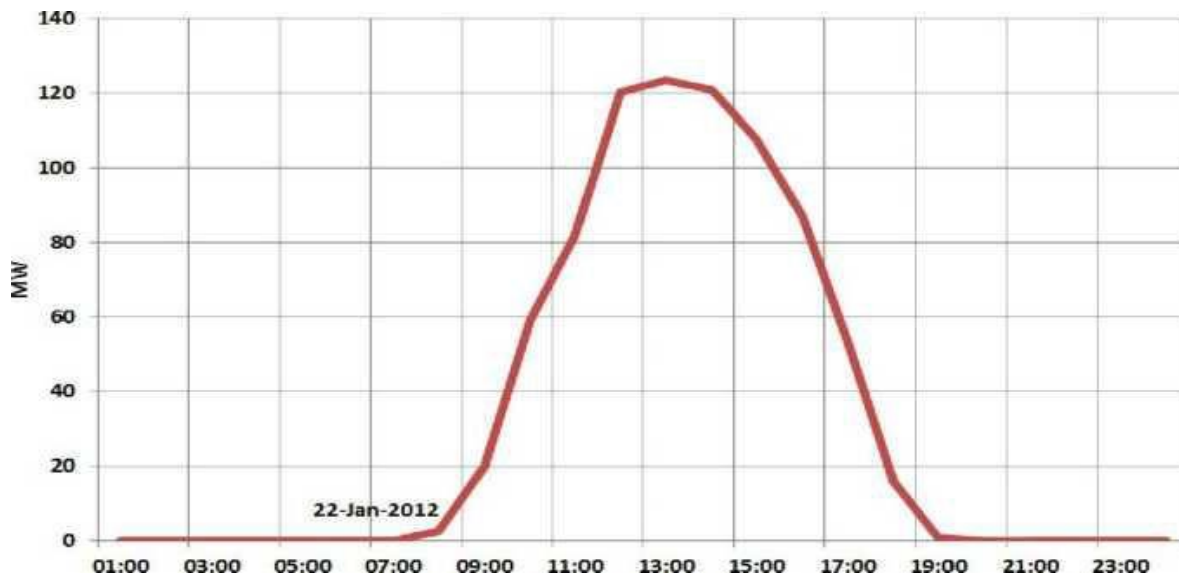

CONCEPTS OF PROTECTION RELAY SYSTEM FOR SMART GRID

In recent years, trends toward electricity liberalization and the increased importance of environmental issues have led to diversification of power system configurations and characteristics, through the installation of distributed power sources based on photovoltaic and wind power generation technologies. Under these circumstances, there is concern regarding the effect on the reliability of power networks with respect to aspects such as overload, frequency variation, and harmonic content. Against this background, there has been increased focus on the concept of Smart Grid, which has the capability of collecting wide-area power system information on a real-time basis from intelligent power grids using Information and Communication Technology (ICT).

Although the setting values of protection relays in power systems are currently decided based on the power system conditions assumed in advance, instances of unnecessary or missed operations might occur in future due to unexpected power system phenomena or operations. In this paper, the concepts of protection relay systems for Smart Grid are suggested as follows:

(a) Protection relay operation suitable for actual power system characteristics

Evaluation of relay setting values can be performed by means of supervising the operating and non-operating margins of each relay characteristic quantitatively and detecting variations of power system characteristics precisely on a real-time basis utilizing analogue input data under normal and faulted conditions. This approach leads to benefits such as modifications to the setting values suitable for actual power system characteristics, coordination check for each protection relay element based on wide-area data, and critical point detection for system

operations.

(b) Intelligent collection of device data

Each protection relay device is provided with the aforementioned function and carries out first-stage evaluation, before transmitting only the data necessary for analysis. In addition, an agent system is applied, which has the capability of collecting protection relay data intelligently and evaluating data from wide-area protection relays without having any effect on protection functions. This approach can realize updating of applications executed in protection relays without needing to take equipment out of service.

Examples of the Protective Relay Applications

This section contains the examples of the protective relay applications that make use of the communication infrastructure provided by the Smart Grid.

A) Dynamic Settings based on Smart Grid Measured Factors:

- Load, Voltage Based
- Feeder Configuration based
- Seasonal Changes / Temperature
- Distributed Generation / Variable In-feed

B) Reclosing Supervision based on Smart Grid data:

- Based on pre-fault load (cold load pickup)
- Based on Fault Magnitude
- Based on computed fault location
- Based on FCI data (1st section inhibit)
- Based on Feeder Configuration

C) Conservation Voltage Reduction Supervision based on Smart Grid data:

- Metering data from Relays

D) Fault Locating:

- Pre-fault location using FCIs
- Branch Fault location using FCIs
- Cable/Overhead, Location refinement using FCIs

E) Power Quality Data:

- “Fault Anticipation”. Location using Power Quality from Meters
- Loose terminations

F) Time:

- Local and wide-area

G) Application using Synchrophasors:

Wide-area situational awareness

Wide-area protection

H) Application using GOOSE:

Local and wide-area over a fiber optic network

I) Load Curtailment (Shedding):

At the feeder level from the substation based on real-time loading

On specific feeder subsections based on real time loading and distributed generation

J) System Integrity Protection Schemes

Wide-area or regional coordinated protection using communication infrastructure

HOME-AREA NETWORK

A home area network (HAN) is a network that is deployed and operated within a small boundary, typically a house or small office/home office (SOHO). It enables the communication and sharing of resources (like the Internet) between computers, mobile and other devices over a network connection.

A Home-Area Network (HAN) is an integrated system of smart meter, in-home display, micro generation, smart appliances, smart sockets, HVAC (Heating, Ventilation, Air Conditioning) facilities and plug-in hybrid/electric vehicles. A HAN uses wired or wireless communications and networking protocols to ensure the interoperability of networked appliances and the interface to a smart meter. It also includes security mechanisms to protect consumer data and the metering system.

A HAN enables centralized energy management and services as well as providing different facilities for the convenience and comfort of the household. Energy management functions provided by HAN include energy monitoring and display, controlling the HVAC system and controlling smart appliances and smart plugs. The services provided by HAN for the convenience of the household can include scheduling and remote operation of household appliances as well as household security systems. Home-based multimedia applications such as media centres for listening to music, viewing television and movies require broadband Internet access across the HAN. A separate HAN used for energy services can coexist with the broadband Internet system but there is some expectation that the systems will be merged in the future.

A home area network is a dedicated network connecting devices in the home such as displays, load control devices and ultimately “smart appliances” seamlessly into the overall smart metering system. It also contains turnkey reference designs of systems to monitor and control these networks. Most of our high energy use today comes from heating /cooling, cooking, lighting, washing and drying. These home appliances are beginning to become smart with connectivity features that allow them to be automated in order to reap benefits that smart metering and variable tariffs bring. The utility companies are beginning to be able to better manage the energy demand and perform load balancing more efficiently.

Realizing long-term potential savings in a typical home environment through the smart grid means that technology, legislation and mindset must come together to drive a permanent change in the way that energy consumption is perceived by consumers. Figure 1 demonstrates how smart appliances are interconnected within a HAN.

Home Area Network

Home Area Network (HAN) connects thermostats, refrigerators and other electrical devices in a Smart Home to an energy management system.

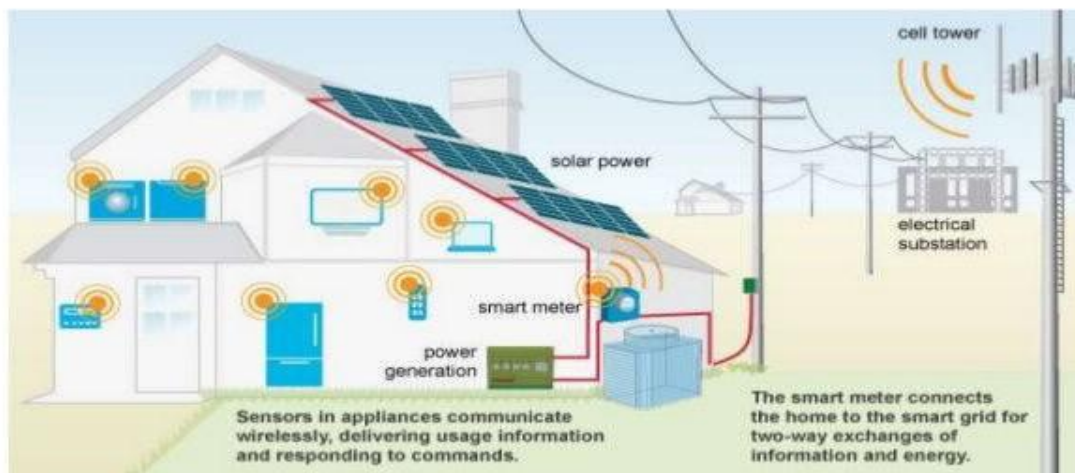

Source: www.smartgridportal.org

PLC Solutions from the Smart Grid to the Home

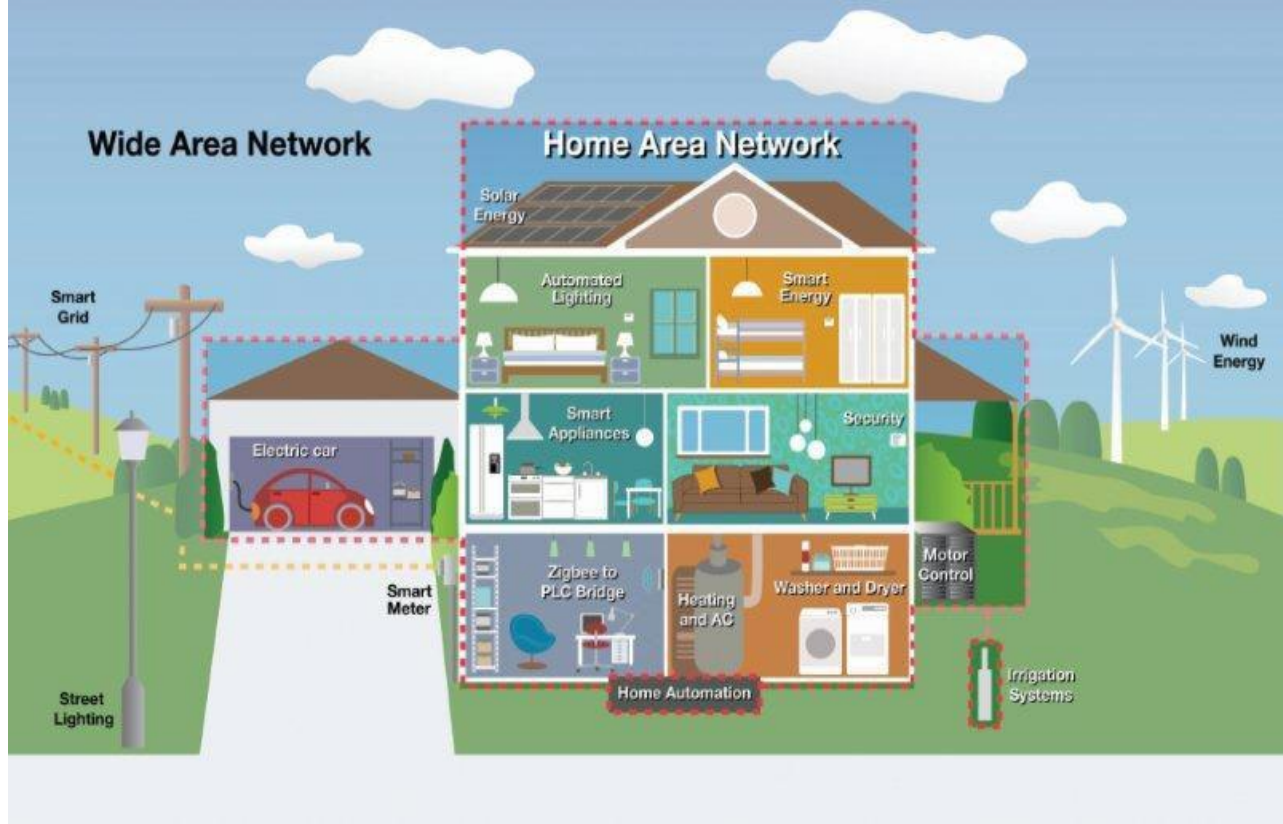

Advantages:

- Hardware and software can be shared.
- All the users work can be stored in a central place.
- Data can be shared because database files stored in the server are available to users around the network.

Disadvantages:

- Printing can be slow, long print queues may develop.
- A virus can spread more easily.
- As data is shared there is a greater need for security.

Plug-in HYBRID ELECTRIC VEHICLES (PHEVs)

Introduction

Plug in hybrid electric vehicles (PHEVs) work similarly to conventional hybrid vehicles in that they can operate using their petrol or diesel engine as well as stored electricity for an electric motor. However, they have much larger batteries than conventional HEV and can also be charged from the mains when not in use in order to maximize the range available to the electric motor. As such, they act as a halfway ground between hybrid electric vehicles and battery electric vehicles.

In addition, most PHEVs (like BEVs and HEVs) would run a regenerative braking system that puts power from braking back into the battery system. All of this allows PHEVs to be very efficient, and if driven for relatively short distances, they could have zero emissions at the point of use.

The benefits of PHEVs are largely similar to those of electric vehicles in that they can, if kept at a high level of charge, operate the majority of the time on electric power, thus reducing their emissions to zero at the point of use. They also have the additional benefits related to electric motors of quiet operation and rapid acceleration. Because of the additional weight of the battery packs, PHEVs tend to be smaller vehicles, usually in the car and small van sector.

There are two key types of PHEV. The first can run indefinitely with the petrol/diesel motor providing the car with the energy required for motion. The second is effectively a battery electric vehicle with a small onboard generator to allow the range of the vehicle to be extended.

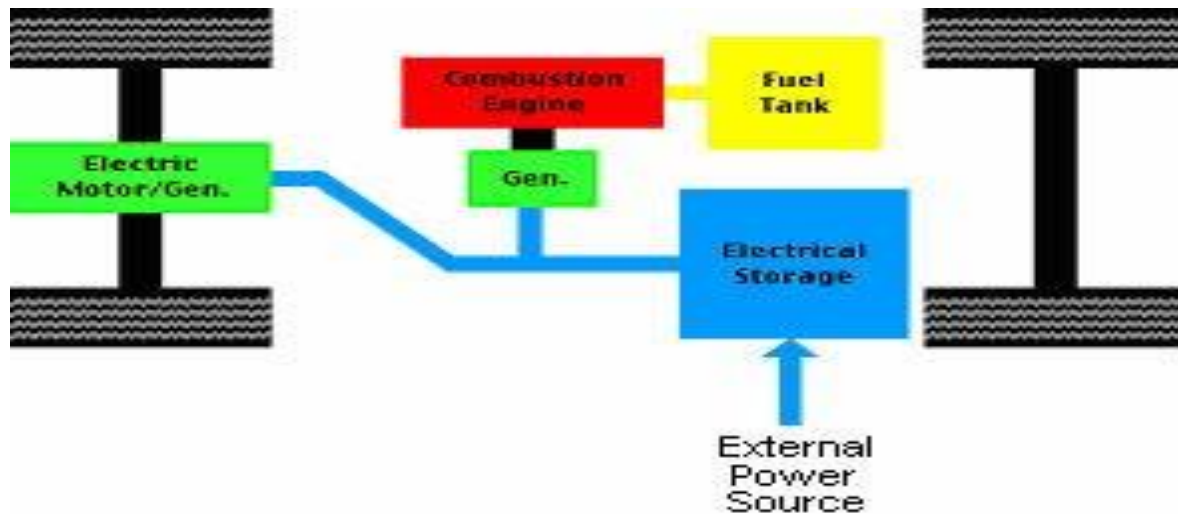

Types by nature of the power source

1. Electric-internal combustion engine hybrid
2. Fuel cell hybrid
3. Human power and environmental power hybrids
4. Pneumatic hybrid
5. Hydraulic hybrid

Advantages

- Improvements in fuel consumption
- Reduction of in-use emissions – potentially to zero
- Cheap to run

Disadvantages

- High capital cost
- Lack of availability
- Limited range in some types
- Emissions can simply be transferred to production sources

Technology details

It is very similar to that of a series hybrid but with a larger electrical storage capacity. This enables the greater range available to these types of vehicles before the combustion engine has to kick in. The type of PHEV which cannot operate independently of recharging would have a very similar layout, the only difference being the combustion engine and generator would be insufficient to keep the electrical storage topped up under normal driving conditions but would slow the rate of depletion of the power stored in the batteries.

PHEVs also usually incorporate other technologies to aid their day-to-day operation. For example, regenerative braking allows energy that would otherwise be wasted as heat during braking to be recycled back into the electrical storage system. This improves the overall efficiency of the vehicle and can significantly improve the range.

1. Battery charging

PHEVs typically require deeper charging and discharging than conventional hybrids. As the number of full cycles affects battery lifetime, battery life may be less than for conventional hybrids which do not deplete their batteries as often.

2. Vehicle availability

There are no plug-in hybrid electric cars or buses currently available for sale in Ireland. It is envisaged that they will be available for purchase in the next few years.

A variety of companies are currently producing Plug-in hybrid vans such as Mercedes-Benz/DaimlerChrysler (Germany/USA), UQM Technologies.

3. Emissions performance

The combination of the internal combustion engine and the electric motor helps hybrid cars perform more efficiently, cutting down on fuel use. Plug-in hybrids have the additional advantage that they can operate purely on electricity from the grid for short distances, so reducing net emissions significantly over regular hybrids.

4. Capital and operating costs

As with regular hybrid electric vehicles, the introduction by manufacturers of more mass-market plug-in hybrid electric vehicles is expected to rapidly drive down the cost of electric drive components. At present however, plug-in hybrids have greater total ownership costs than conventional vehicles. This is due to the much greater capital costs involved when purchasing plug-in hybrids.

Comparison Between PHEVs and EVs

Sl.No	Description	PHEVs	EVs
1	Infrastructure:	<ul style="list-style-type: none">• Home recharging will be a prerequisite for most consumers; public recharge infrastructure may be relatively unimportant.	<ul style="list-style-type: none">• Greater need for public infrastructure to increase daily driving range; quick recharge for longer trips and short stops
2	Economies of scale:	<ul style="list-style-type: none">• Mass production levels needed to achieve economies of scale may be lower than those needed for EVs.	<ul style="list-style-type: none">• Mass production level of 50 000 to 100 000 vehicles per year, per model will be needed to achieve reasonable scale economies.
3	Vehicle range:	<ul style="list-style-type: none">• PHEV optimal battery capacity (and range on grid-derived electricity) may vary by market and consumer group.	<ul style="list-style-type: none">• Minimum necessary range may vary by region – possibly significantly lower in Europe and Japan than in North America.

4	Consumer adoption:	<ul style="list-style-type: none"> • Many consumers may be willing to pay some level of price premium because it is a dual-fuel vehicle. • People interested in PHEVs may focus more on the liquid fuel efficiency (MPG) benefits rather than the overall energy efficiency. • Electric range should be set to allow best price that matches the daily travel of an individual or allow individuals to set their own. 	<ul style="list-style-type: none"> • Early adopters may be those with specific needs, such as primarily urban driving, or having more than one car. • With involvement from battery manufacturers and utilities, consumers may have a wider range of financing options for EVs • EVs will perform differently in different situations (e.g., weather) and locations.
5	Procedures	SAE J1711 and UNECE R101 adopted test procedures for measuring PHEV fuel economy and electric energy consumption	SAE J1634 and UNECE R101 adopted test procedures for measuring EV electric energy consumption.

SUPERCAPACITORS

Supercapacitors, ultracapacitors (commercial denominations given originally by its manufactures Nippon Electric Company, NEC, in Japan, and by Pinnacle Research Institute, PRI, in USA) or electrochemical double-layer capacitor (EDLC, technical name) are devices that can be used as energy storage systems, that have high energy and power densities, a high efficiency, nearly 95% and a large life expectancy.

Supercapacitors store charge in a similar way to conventional capacitors, but the charge does not accumulate in two conductors, but in the interface between the surface of a conductor and an electrolytic solution.

Supercapacitor devices consist of two electrodes which allow a potential to be applied across the cell, therefore they present two double-layers, one at each electrode/electrolyte interface. An ion-permeable separator is placed between the electrodes in order to prevent

electrical contact, but still allows ions from the electrolyte to pass through. The electrodes are made with high effective surface materials, such as porous carbon or carbon aerogel. Two principal technologies are used: aqueous (maximum voltage of 1.2 V and work voltage of 0.9 V) and organic (voltage near 3 V but with a much higher series resistance).

The principal supercapacitor characteristic that makes it suitable for using in ESS, is the possibility of fast charge and discharge without loss of efficiency, for thousands of cycles. This is because they store electrical energy directly. Super capacitors can recharge in a very short time having a great facility to supply high and frequent power demand peaks.

Supercapacitor can be manufactured in any size because they do not need a dielectric, from high capacitance superSupercapacitors for hybrid vehicles, to small capacitance ones to be used in low power applications such as wireless systems.

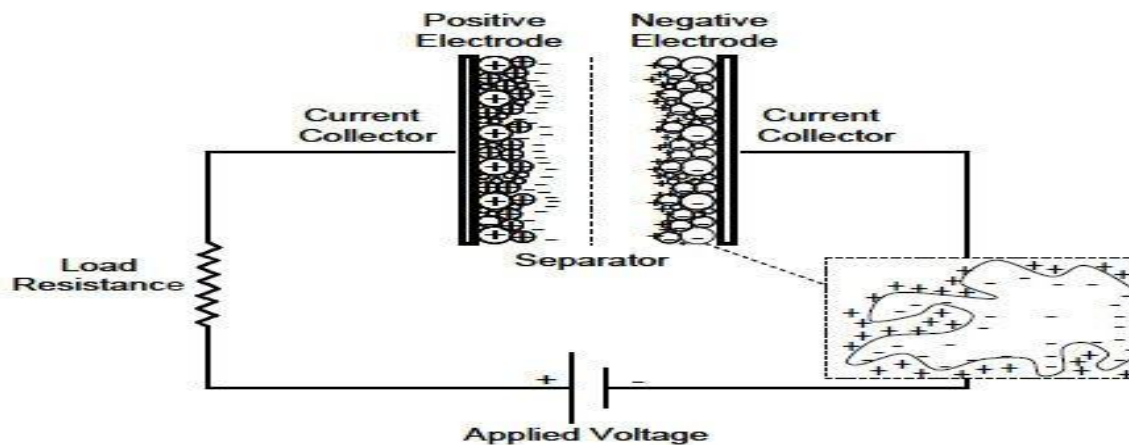

Double-layer capacitors - with carbon electrodes or derivate with much higher static double-layer capacitance than the faradaic pseudo-capacitance

Pseudo-capacitors - with electrodes out of metal oxides or conducting polymers with a high amount of faradaic pseudo-capacitance

Hybrid capacitors - capacitors with special and asymmetric electrodes that exhibit both significant double-layer capacitance and pseudo-capacitance, such as lithium-ion capacitors

Supercapacitors principles and models

Supercapacitors are based on the same physical principles as conventional capacitors, but the first ones present a higher area and thinner electrodes (with lower electrodes distances) than the second ones. This increases the capacitance values and the energy that can store. An estimation of the capacitance value can be obtained from the double-layer model proposed by

Helmholtz in 1853, considering the double-layer charge as two charge monolayers. The specific capacitance of such a double-layer is given by

$$C = \epsilon_0 \epsilon_r \frac{A}{D}$$

where C is the capacitance, ϵ_0 the dielectric constant of free space, ϵ_r the dielectric constant of the medium between the two layers, A the surface area, and D is the distance between the two layers (the distance from the electrode surface to the centre of the ion layer). This approximation is roughly correct for concentrated electrolytic solutions.

The energy stored in a supercapacitor, as in a conventional capacitor, is

$$E = \frac{1}{2} CV^2$$

where V is the supercapacitor voltage.

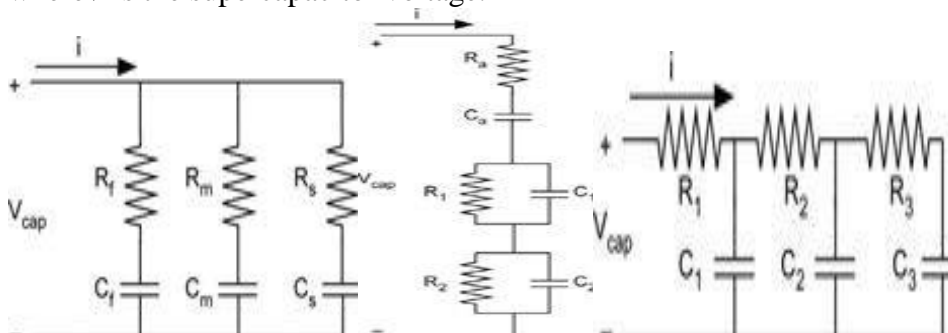

The simplest equivalent circuit to model a supercapacitor is a capacitor, C , with an equivalent series resistance (ESR), R , which represents the Joule losses. More detailed supercapacitor RC models are various parallel RC branches (Fig. (a)); RC series-parallel branches (Fig. (b)); and transmission line model (Fig. (c))

Advantages Over Batteries

- Power density
- Recycle ability
- Environmentally friendly
- Safe
- Light weight

Applications for Supercapacitors

- Computer systems - Power generators
- UPS systems - Battery assist
- Power conditioners - Smart meters

- Welders - Energy harvesting
- Inverters - Medical systems
- Automobile braking systems - Audio systems
- Power supplies - Emergency lighting
- Cooking equipment - Electric valves/ solenoids

SUPER CONDUCTING MAGNETIC ENERGY STORAGE (SMES)

In this system, a magnetic field is created by direct current passing through a superconducting coil. A typical SMES system includes three parts: superconducting coil, power conditioning system and cryogenically cooled refrigerator. Once the superconducting coil is charged, the current will not decay and the magnetic energy can be stored indefinitely. In a superconducting coil, resistive losses are negligible and so the energy stored in the magnetic field does not reduce in time. In order to maintain the superconductivity of the SMES coil, a cryostat which can keep the temperature of the coil below the superconductor temperature limit is required. The optimum operating temperature of high temperature superconductors that are favored for energy storage applications is around 50-70K. Further, as the magnetic field produced by a SMES is large, a strong supporting structure is needed to contain the electromagnetic forces. The stored energy in the SMES is retrieved when required by a power conditioning system that is connected to the AC network. SMES loses the least amount of electricity in the energy storage process compared to other methods of storing energy.

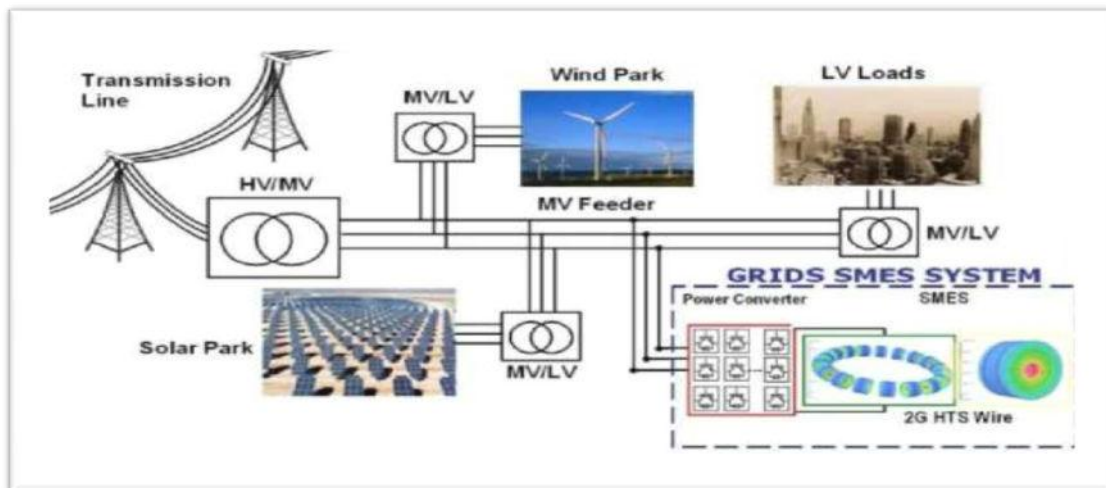

Fig :Superconducting Magnet Energy Storage (SMES) System with Direct Power Electronics Interface for GRIDS

A Superconducting Magnetic Energy Storage system stores the energy as magnetic energy in a superconducting magnet cryogenically cooled, achieving a system with negligible losses. The AC energy is stored as DC energy and brought back from DC to AC energy from the superconducting magnet by a reversible AC/DC Power Converter Module (PCM).

The superconducting magnet can present two different shapes: toroid or solenoid. The first has a lower external field but higher superconductor and components cost than the second. The energy stored by an SMES is

$$E = \frac{1}{2} LI^2$$

where L is the equivalent self-inductance of the superconductor system, and I is the DC current that flows through the winding. This current is the principal magnitude that the PCM uses for controlling the energy stored or generated by the system.

SMES efficiency is between 95 % and 98 %. It has a high availability, being able to supply high energy quantity in time intervals of milliseconds.

First SMES systems (in the 1970s) were focused for large scale applications, with energy storage capacities between 1,000 and 10,000 MWh, powers about 1,000 MW (for 5,000 MWh applications and were underground systems. Application of superconducting in SMES took place for the first time in 1974 in Los Alamos National Laboratory (LANL) using a three-phase converter. Bonneville Power Authority (BPA) and LANL team designed in 1976 a SMES of 8.33 kWh (30 MJ) and 10 MW. At present, typical SMES Systems are designed with an energy storage capacity of from 0.15 kWh (600 kJ) to 28 kWh (100 MJ).

The main disadvantage of the SMES system is that the energy density is low and there is a need for a criogenization system that could be very complex for large scale application. A possible solution is to combine them in hybrid ESS increasing their energy and power.

Features of SMES

- Capability of absorbing and delivering large amounts of power.
- High efficiency.
- Long lifetime.
- Short response time.

- Completely static construction, low maintenance.
- All electric energy storage

ADVANCED ENERGY STORAGE TECHNOLOGY

Humanity is demanding a bigger quantity of energy as its level of development is growing. Conventional energy resources are limited, so authorities and governments are promoting energy savings and energetic efficiency. Also, renewable energies have been sustained and promoted by these authorities and governments as an alternative to limited conventional energy resources.

Nowadays, the most relevant renewable energies used in generation plants are solar (photovoltaic or thermal) and wind energy. The main disadvantage of these kinds of renewable energy is its generation discontinuity, as well as the fact that its energy generation is not controlled by the system operator thus making it more difficult to integrate these plants in the generation pool than in the case of conventional plants.

Energy storage becomes a critical factor that can solve the problems described above. A renewable energy generation plant with its corresponding energy storage system can behave as a constant power generation plant (following the reference power generation given by the regulator), at least for time intervals in the order of half an hour to a day, depending on the energy storage capacity.

Large quantity of electrical energy can be stored using pumped hydro or underground compressed air facilities. Similarly quantities of energy can be stored in batteries, fly wheels and Superconducting Magnetic Energy Storage (SMES) devices. Fuel cells convert a continuous source of chemical energy into electricity but have a similar impact on the power network as some energy storage systems. A comprehensive comparison and assessment of all storage technologies is given in Figure 3-1.

Energy Storage Systems

The principal energy storage systems (ESS) are summarized in Fig. 1, where these systems are classified according to their application. We will focus this paper on the systems classified into the Large Scale (>50 kW) in this figure.

Most relevant ESS technology characteristics are summarized in Table I. The ESS considered for medium scale applications are classified in Fig. 2 by their power and energy densities.

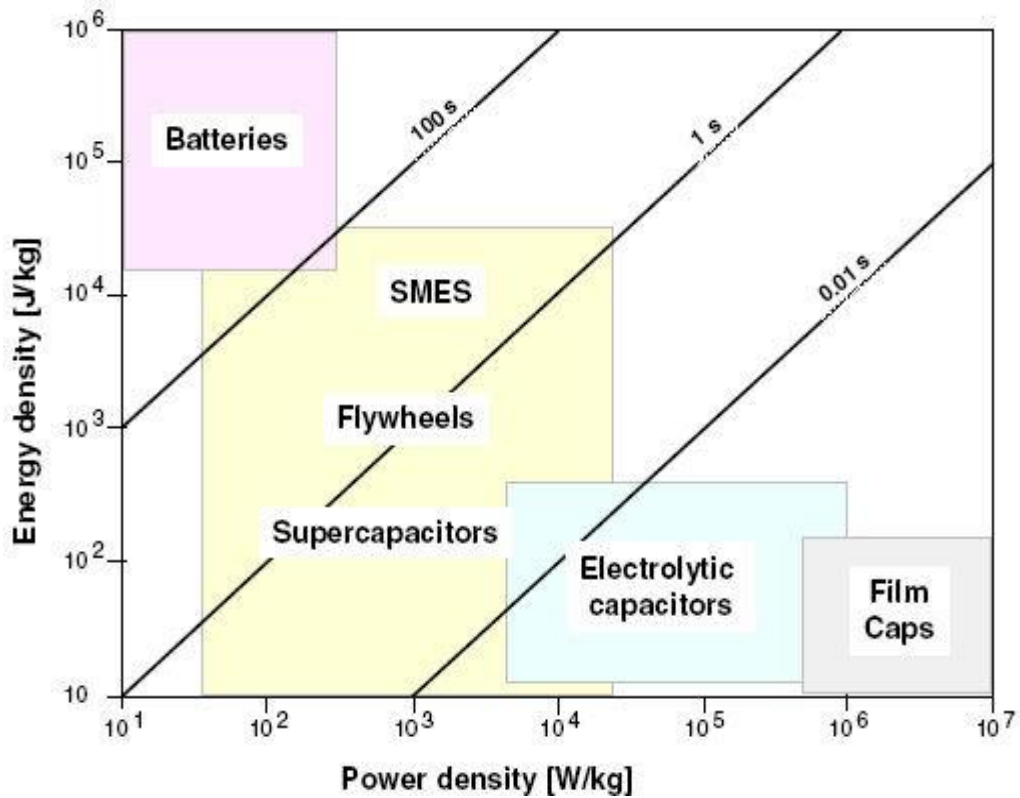
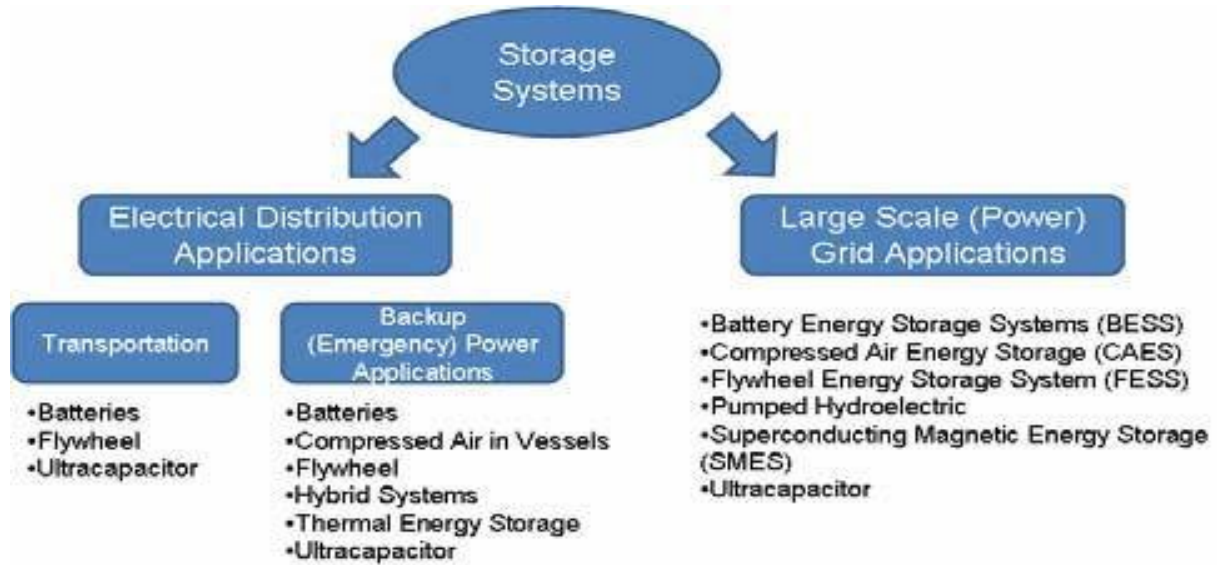

Some of the applications of energy storage are as follows:

- **Power Quality:** Battery energy storage is used in Un-interruptible Power Supplies to mitigate short-term loss of power and power fluctuations. Energy storage can also be used to mitigate voltage fluctuations and improve some other power quality issues such as harmonics.
- **Service provision to renewable generation:** Energy storage could be a support for integration of renewable energy sources that is having intermittent supply and lack of controllability as their inherent characteristics. Energy storage can smooth the output of renewable energy sources and matches the energy demand. Battery energy storage can also smooth the output power of wind farms.
- **Electrical Energy time shifting:** Energy can be stored when demand is low or at times when the price is low and discharging the energy when demand is high or at times when the price is high. It also supports distribution networks by relieving congestion during peak demand periods by supplying locally.
- **End use energy management:** Energy storage could provide benefits to end users who are on time-of-use tariff through electrical energy time shifting or who have micro generation.
- **Voltage Support:** In distribution network, both active and reactive power needs to be used for voltage control due to low X/R ratio of the network. Distributed energy storage may be attractive as it can provide both active and reactive power and control voltage while reducing the reactive power flows in the network.
- **Reserve:** Energy storage as an ancillary service can be used to maintain system stability under unexpected connection/disconnection of load/generation.
- **Load following:** The energy storage can be used as a good ancillary service for the utilities experiencing frequently changing power demand as their response is quick with a high efficiency.

Batteries

Batteries store energy in chemical form during charging and discharge electrical energy when connected to a load. In its simplest form, a battery consists of two electrodes, a positive and a negative placed in an electrolyte. The electrodes exchange ions with the electrolyte and electrons with external circuit. Structure of a typical lead acid-battery is shown in Figure 3-2.

Lead acid and Sodium Sulfur (NaS) batteries are used at present for large utility applications in compatible numbers. Lithium Ion (Li-ion), Nickel Cadmium (NiCd) and Nickel metal hydrides (NiMH) are also thought to be promising future options. Lead acid batteries have been used for many years in utility applications, providing excitation for synchronous machines and acting as backup auxiliary power supplies. They are cheap but need significant maintenance and their lifetime becomes short when discharged deeply.

NaS batteries operate at 300-400°C and have large energy capacity per unit volume and weight. A NaS battery is a molten-metal battery with molten sulfur as the positive electrode and molten sodium as the negative. The electrodes are separated by a solid ceramic, sodium alumina, served as the electrolyte. Figure 3-3 shows a 34MW NaS Battery installation in Japan. Mainly they are used for electrical energy time shifting, wind farm support, and to smooth the output of PV generators.

Li-ion batteries are taking its place as a distributed energy storage system, in particular with the developing use of Li-ion batteries in electric vehicles and for energy storage with renewable generation. These have a graphite negative electrode and lithium cobalt oxide, lithium iron phosphate or lithium manganese oxide positive electrode. The electrolytes generally use lithium salt in an organic solvent. A 5MW Li-ion battery Storage system typical installation is shown at Figure 3-4. The life cycle of the Li-ion batteries are comparatively much higher than that of lead acid batteries.

Nickel Cadmium (NiCd) batteries are extensively used for power tools, mobile phones and laptops. The robust nature of technology, combined with its energy density, gives it advantages over lead acid.

FLOW BATTERY

A flow battery uses two electrolytes, often different kinds of the same chemical compound. Both the positive and negative electrolytes are stored separately and are pumped through a cell. Inside the cell, the two electrolytes are kept separate. The electrochemical reaction takes place by transferring ions across a membrane as shown in **Figure**. The electrodes do not take part in the chemical reaction and thus do not deteriorate from repeated cycling.

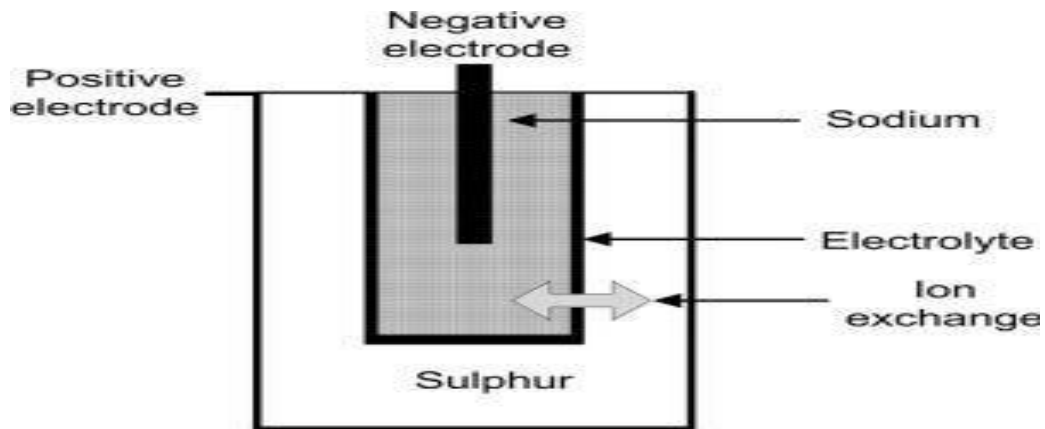
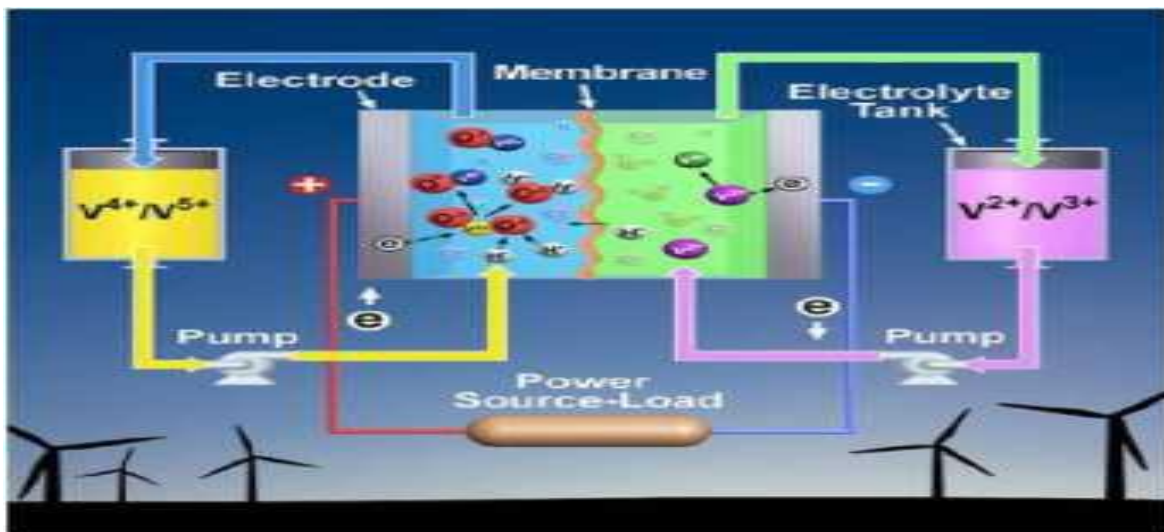
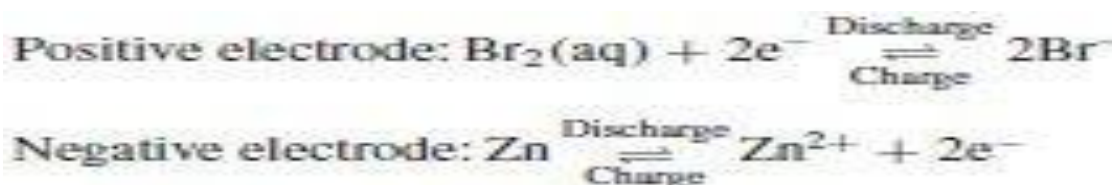

Fig : A NaS Battery



The amount of energy stored in a flow battery depends on the volume of the electrolyte in the tanks whereas the power output depends on the speed of ion transfer across the membrane. Flow batteries using Zinc Bromide (ZBB) and Vanadium Redox (VRB) are available. A ZBB consists of a zinc negative electrode and a bromine positive electrode separated by a micro porous membrane. An aqueous solution of zinc bromide (ZnBr) is circulated through the two compartments of the cell from two separate reservoirs as shown in **Figure**. On discharge, the zinc is oxidised, giving zinc ions, and the bromine is reduced to bromide ions. During charging, zinc is electroplated on the negative electrode and bromine is evolved at the positive electrode; this is stored as a chemically complex organic phase at the bottom of the positive electrolyte tank. A third pump is used for recirculation of the organic phase during the discharge cycle.

The reactions that occur at the two electrodes during charge and discharge are:



In VRB, V^2/V^3 and V^4/V^5 redox couples in sulphuric acid are stored in electrolytic tanks with an ion exchange membrane. The reactions that occur in the battery during charging and discharging are:

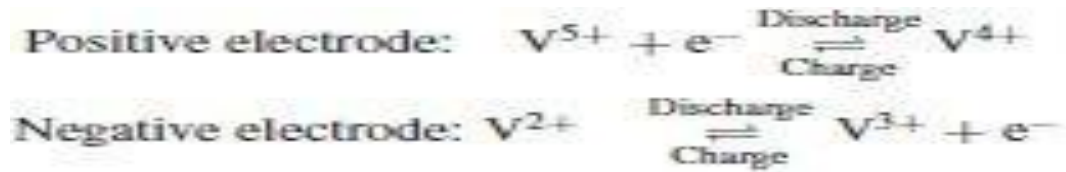

There have been a number of demonstration projects with flow batteries of capacities ranging from a few kW to several MW with storage up to 10 hours at full output.

Applications

- [Loadbalancing](#)
- Storing energy from renewable sources
- Peak shaving, where spikes of demand are met by the battery.
- [UPS](#), where the battery is used if the main power fails to provide an uninterrupted supply.
- [Power conversion](#) – because all cells share the same electrolyte/s.
- [Electric vehicles](#) – Because flow batteries can be rapidly "recharged"
- [Stand-alone power system](#).

FUEL CELL

Similar to a battery, a fuel cell is a device that converts chemical energy directly into electrical energy. However, unlike batteries, with non-stop supply of fuels, fuel cell can run forever and produce steady supply of electrical energy. The two basic components used to run a fuel cell are hydrogen and oxygen. They react inside the fuel cell to generate electricity heat and water. This new energy source will never be used up as we have unlimited supply of oxygen on Earth. Hydrogen can be produced from water, gasoline, natural gas, landfill gas, coal based gas, methane, methanol and ethanol. Most of the fuel cells use hydrogen and oxygen as their main fuel. At the negative electrode hydrogen is oxidized to form proton and electron. The electrons flow through the external electrical circuit whereas the hydrogen ions move towards the positive electrode through the electrolyte. The positive electrode is made from a porous material coated with a catalyst. At that electrode, the hydrogen ions combine with oxygen to produce water.

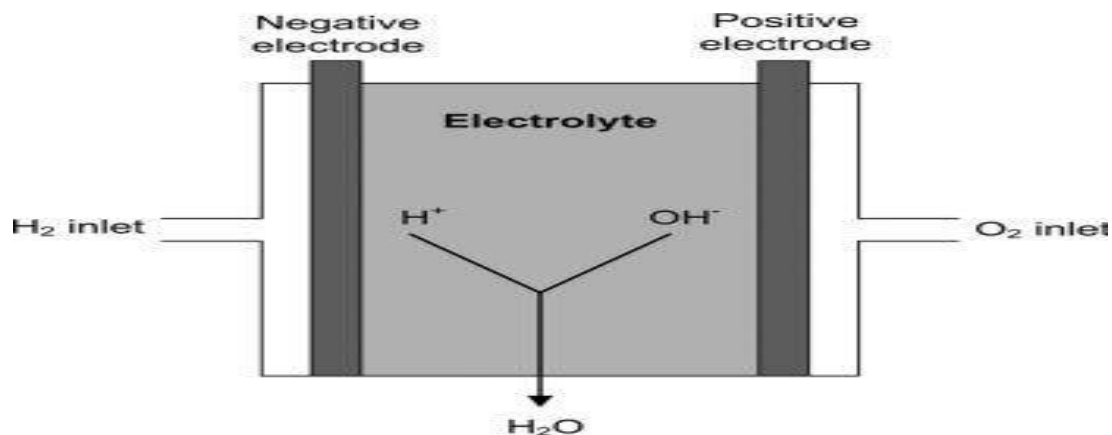
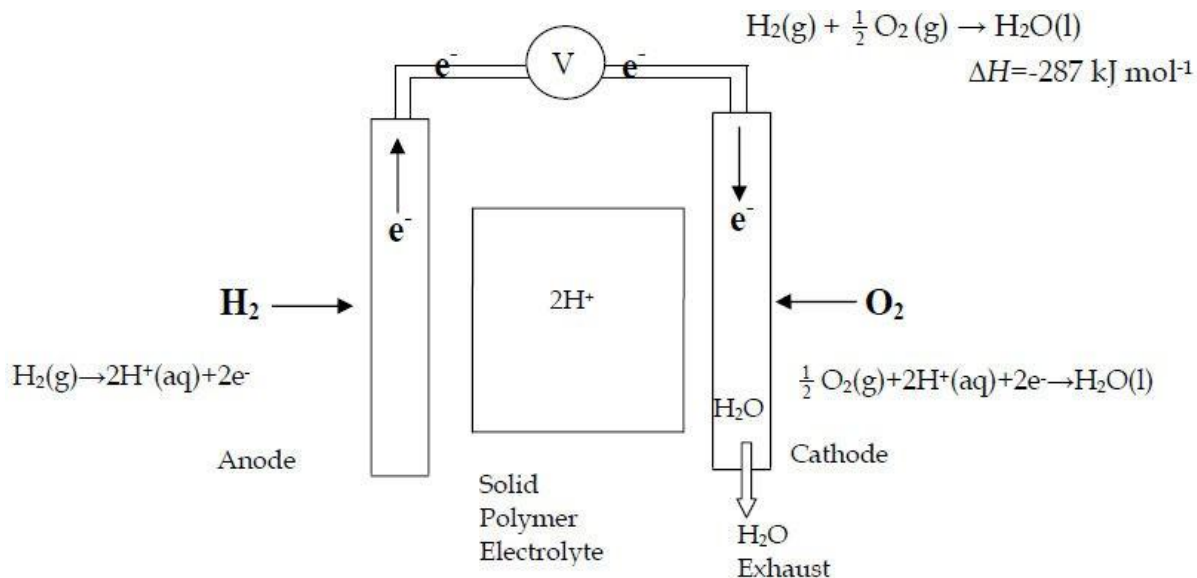

Fig : Fuel Cell

Working

A fuel cell consists of two electrodes, the anode and the cathode, separated by an electrolyte. Thin layer of platinum or other metals, depending on the type of the fuel cell, is coated on each electrode to activate the reaction between oxygen and hydrogen when they pass through the electrodes. The overall reaction is shown by the equation below:



TYPES

There are five major types of fuel cells being known or used in the market..

- ◆ Alkaline Fuel Cell (AFC)
- ◆ Phosphoric Acid Fuel Cell (PAFC)
- ◆ Molten Carbonate Fuel Cell (MCFC)

- ◆ Solid Oxide Fuel Cell (SOFC)
- ◆ Proton Exchange Membrane Fuel Cell (PEMFC)

APPLICATIONS

- Space Exploration
- Transportation
- Stationary and Residential Applications
- Portable Power for Electronics
- [Distributed generation](#)
- [Emergency power systems](#)
- [Hybrid vehicles](#),
- [Smartphones](#), laptops and tablets.

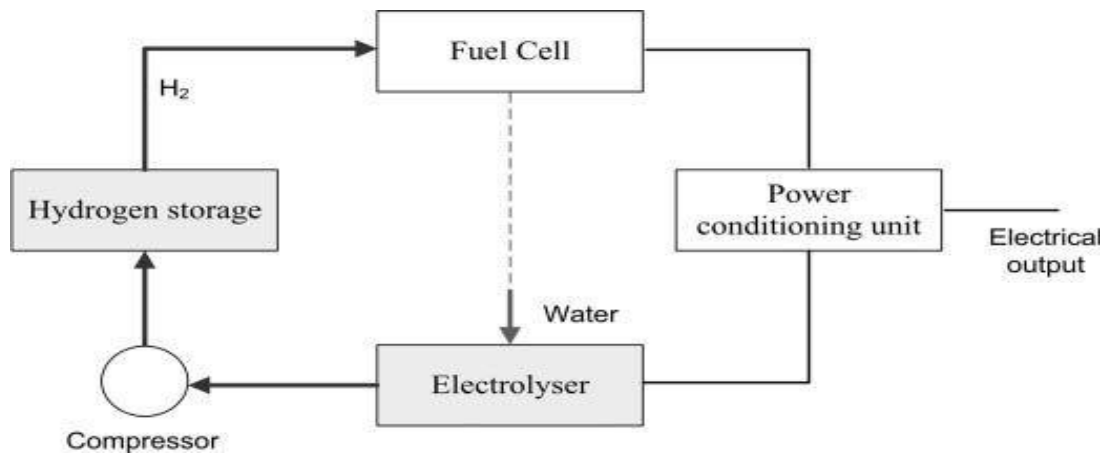

Fig : Hydrogen energy storage system

Hydrogen based energy storage systems consist of an electrolyser, hydrogen storage and a fuel cell. The electrolyser uses electrical energy to produce H₂ from water. One of the potential applications of this device is to store H₂ from water when there is excess wind energy generation and then use the stored H₂ to support the power system during peak demand periods.

Regenerative fuel cells which consume electricity and act as an electrolyser (to produce H₂) have also been developed.

FLY WHEELS

Flywheels store kinetic energy in a rotating mass and release it by slowing the rotation when electrical energy is required. Their application to date has mainly been for power quality and to provide energy for UPS. The majority of installations are on consumers' premises with a very few applications in demonstration micro-grids. Flywheels are not as adversely affected by temperature changes, can operate at a much wider temperature range, and are not subject to

many of the common failures of chemical rechargeable batteries. They are also less potentially damaging to the environment, being largely made of inert or benign materials.

Consider the simple rotating disc shown in **Figure**. The stored energy is proportional to the square of the rotor speed (ω) and the moment of inertia of the rotating mass (J):

$$\text{Stored Energy} = \frac{1}{2} J \omega^2$$

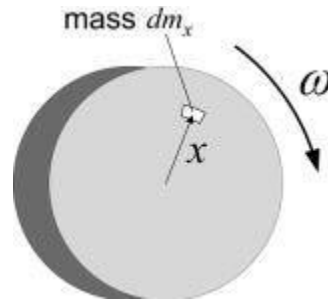

The moment of inertia is given by:

$$J = \int x^2 dm_x$$

where x is the distance to an element of mass dm_x from the axis of rotation.

From Equation , it is clear that to store energy, two options can be used: a low speed flywheel which uses a heavy steel rotor with high inertia or a high speed flywheel which uses lighter composite materials.

As given in Equation, the location of the mass is important. In some designs the mass is formed as a rim, placed away from the axis of rotation, to maximize the moment of inertia. High speed flywheels, which rotate at up to 50,000 rpm, operate in a vacuum with magnetic bearings in order to reduce friction losses. A cross-section of a flywheel is shown in **Figure** .

A **flywheel** is a rotating mechanical device that is used to store [rotational energy](#). Flywheels have an inertia called the [moment of inertia](#) and thus resist changes in rotational speed. The amount of energy stored in a flywheel is proportional to the square of its [rotational](#)

speed. Energy is transferred to a flywheel by the application of a torque to it, thereby increasing its rotational speed, and hence its stored energy.

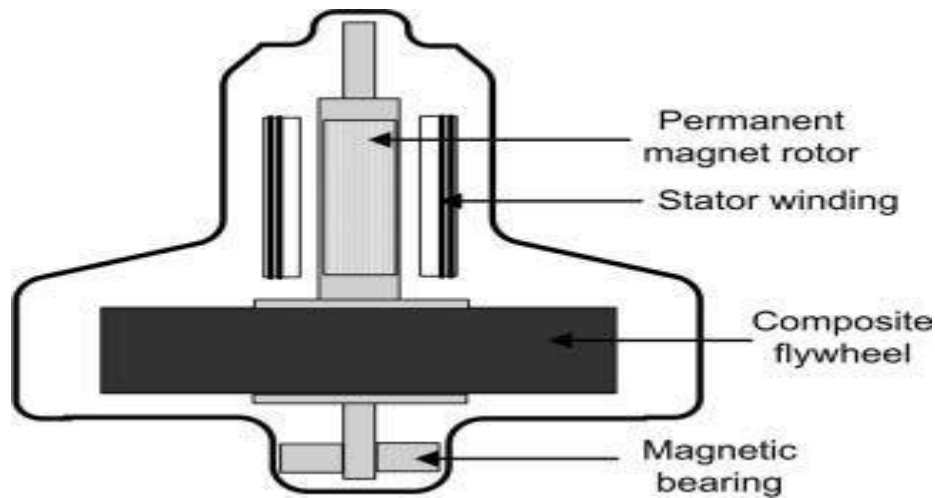

Fig : Cross Section of Flywheel

APPLICATIONS

Flywheels are used in Buses, Cars, Container Cranes, Construction Machines, Garbage Trucks, Charging Stations, Train Stations, Trams, Micro-Grid Stabilization and Power Quality.

Case study 1: Energy storage for wind power

The BES system uses a multi-modular converter shown in Figure 12.14a. The switches in each bridge are switched to obtain a step-wise output as shown Figure 12.14b.

During the positive half cycle, all the upper switches on the first arm of the bridges (S1 to S6) were on; whereas during the negative half cycle, all the lower switches on the first arm ($\bar{S}1$ to $\bar{S}6$) were on.

Within a half-cycle, staircase modulation was achieved by switching the switches of the second arm. In order to obtain a step of V_{dc} , one lower switch of the second arm was turned on. For example, when S11 was on and all the other lower switches of the second arm (that is, S21, S31, S41, S51 and S61) were off, the output, V_o , was equal to V_{dc} . To obtain a step of $2V_{dc}$, two lower switches of the second arm were turned on. Finally, to obtain $6V_{dc}$, all the lower switches of the second arm of the bridges were turned on.

Table 12.2 shows one possible combination of switching status during the positive and negative half cycles. The switches which were turned on were cyclically varied so as to extract

equal amounts of energy from each battery. That is, during the first cycle, Bridge 1 was used to obtain V_{dc} ; whereas during the second cycle, Bridge 2 was used to obtain V_{dc} . Turn-on times (β_1, β_2 , and so on) were obtained by an optimisation routine where the error between the waveform shown in Figure 12.14(b) and a sinusoidal waveform was minimised.

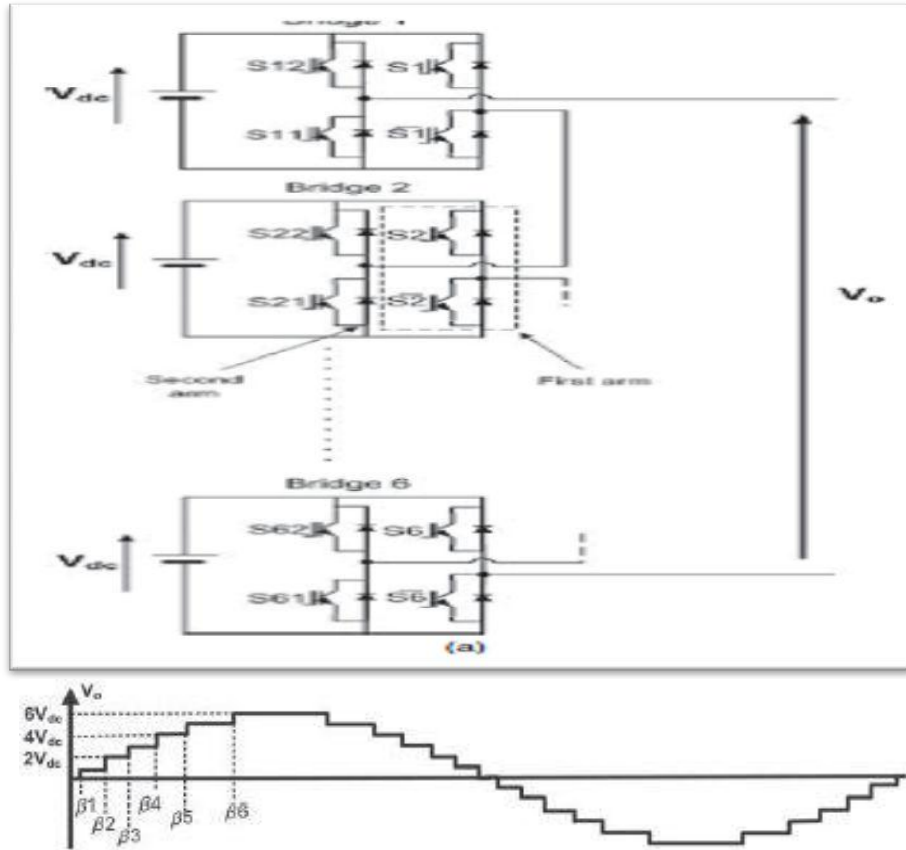
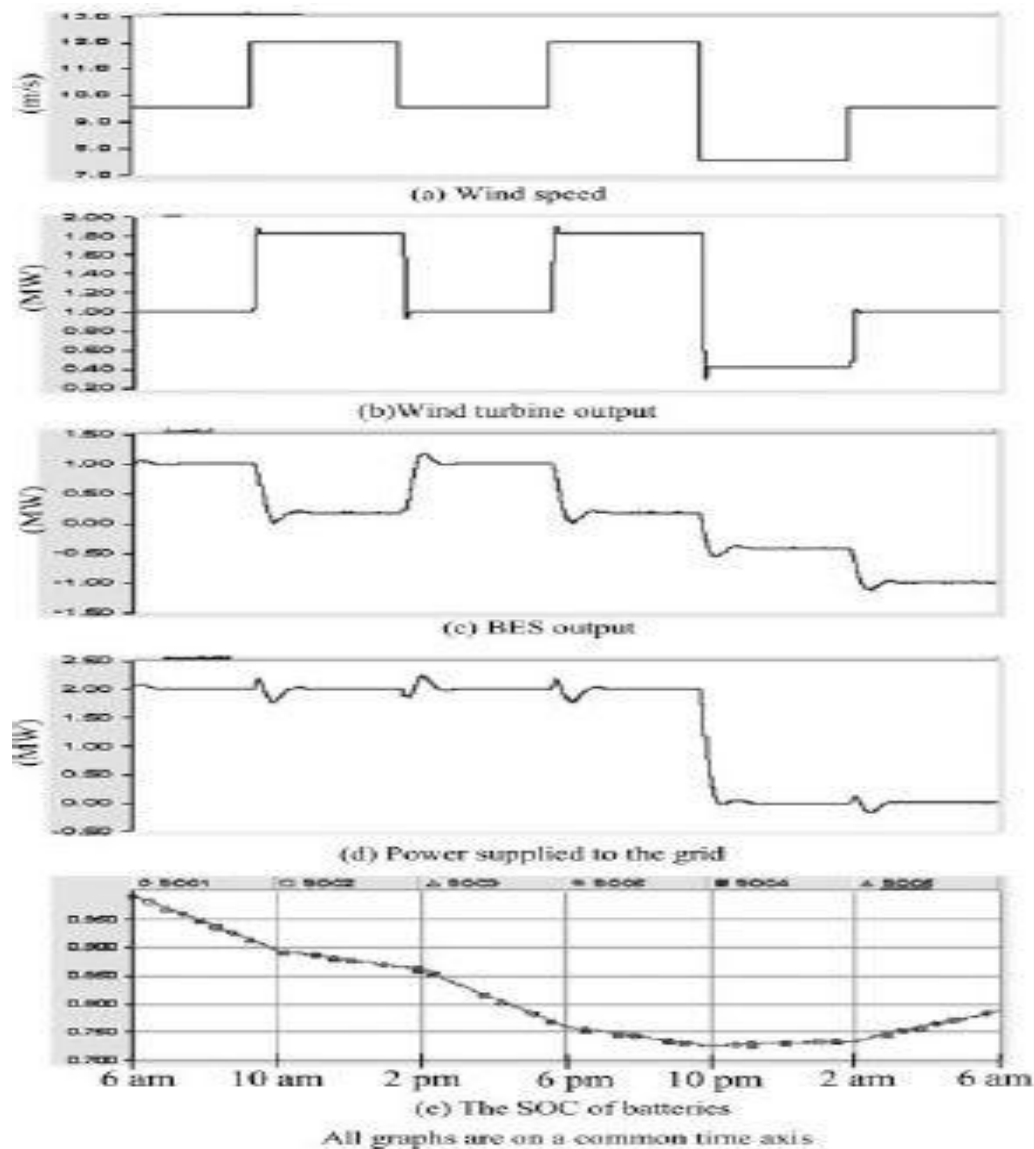

Figure 12.14 Inverters and Waveforms

Table 12.2 One possible switching combination

During the positive half cycle									
V_o	S_1 to S_6	\bar{S}_1 to \bar{S}_6	S_{11}	S_{21}	S_{31}	S_{41}	S_{51}	S_{61}	S_{12} to S_{62}
0	0	0	0	0	0	0	0	0	0
$V_{dc}/6$	1	0	1	0	0	0	0	0	0
$2V_{dc}/6$	1	0	1	1	0	0	0	0	0
$3V_{dc}/6$	1	0	1	1	1	0	0	0	0
$4V_{dc}/6$	1	0	1	1	1	1	0	0	0
$5V_{dc}/6$	1	0	1	1	1	1	1	0	0
$6V_{dc}/6$	1	0	1	1	1	1	1	1	0
During the negative half cycle									
V_o	S_1 to S_6	\bar{S}_1 to \bar{S}_6	S_{12}	S_{22}	S_{32}	S_{42}	S_{52}	S_{62}	S_{11} to S_{61}
$-V_{dc}/6$	0	1	1	0	0	0	0	0	0
$-2V_{dc}/6$	0	1	1	1	0	0	0	0	0
$-3V_{dc}/6$	0	1	1	1	1	0	0	0	0
$-4V_{dc}/6$	0	1	1	1	1	1	0	0	0
$-5V_{dc}/6$	0	1	1	1	1	1	1	0	0
$-6V_{dc}/6$	0	1	1	1	1	1	1	1	0

Using the BES shown in Figure 12.14a, the system shown in Figure 12.13 was simulated. As shown in Figure 12.15a, a varying wind speed was applied to the fixed speed wind turbine. The simulations started at 6 a.m. and finished at 6 a.m. on the next day. From 6 a.m. to 10 p.m. the BES was controlled to maintain the total power supplied to the grid at 2 MW as shown in Figure 12.15d. From 10 p.m. to 6 a.m. the following day, the load was set to zero and the wind power was used to charge the BES. Figure 12.15e shows the State Of Charge (SOC) of each battery bank of the six-level converter. As can be seen, the SOC reduced from 6 a.m. to 10 p.m. and then increased. The SOC in each bridge (SOC1 is the state of charge of the battery in Bridge 1, and so on) was balanced by the cyclic modulation technique.



12.4 Case study 2: Agent-based control of electrical vehiclebattery charging

Many countries are promoting Electric Vehicles (EV) as a means of decarbonizing their transport sectors. From the power system point of view, EVs can be viewed not only as loads but also as distributed energy storage devices. It is anticipated that EVs will communicate with the Smart Grid to provide electrical energy demand-shifting services such as reducing their charging rate or delivering electricity to the grid.

In this case study, two charging regimes, uncontrolled EV charging (where all the consumers charge their EVs just after returning home) and controlled EV charging, were investigated. A Multi Agent System (MAS) was used for controlled EV charging. More information about MAS can be found in.

A residential area having Battery Electric Vehicles (BEV) and Plug-in Hybrid Electric Vehicles (PHEV)³ was considered. It was assumed that there are 32 BEVs and 96 PHEVs. The mean time the EVs were connected for charging was assumed to be 18.00 hrs. The parameters of the EVs are given in Table 12.3.

Table 12.3 Assumed EV parameters

BEV battery capacity (kWh)	28
PHEV battery capacity (kWh)	7.2
EV charge rating (kW)	2.99
EV battery efficiency (%)	85
EV charger efficiency (%)	87
Average EV energy requirement (kWh)	6.5
Average BEV initial State of Charge (%)	40
Average PHEV initial State of Charge (%)	10

An agent architecture was used (Figure 12.16).

1. The Substation Agent (**SA**) is located at the secondary substation at the MV/LV level. It is responsible for managing the battery charging/discharging of the electric vehicles within a LV area.
2. The Vehicle Agent (**VA**) is located at the vehicle and represents an EV owner or an EV Aggregator.⁴ It is responsible for managing the charging/discharging of an individual EV or fleet of EVs.

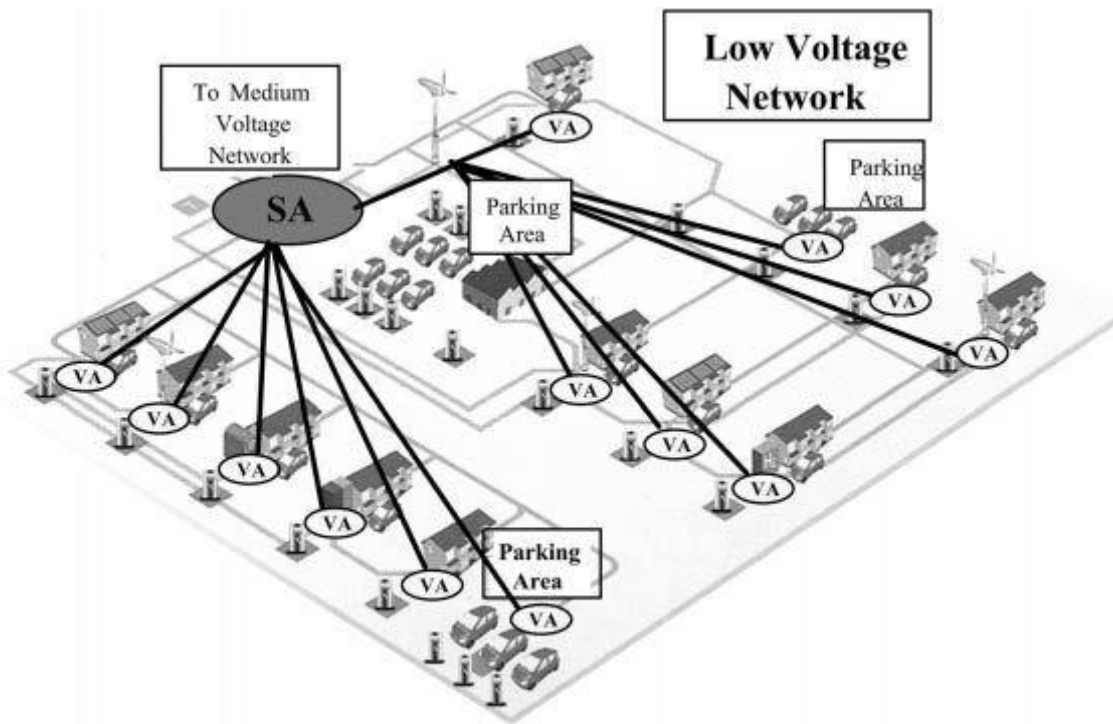

SA – Substation Agent

VA – Vehicle Agent

Figure 12.16 Multi Agent-based Electrical Vehicle charging and discharging architecture

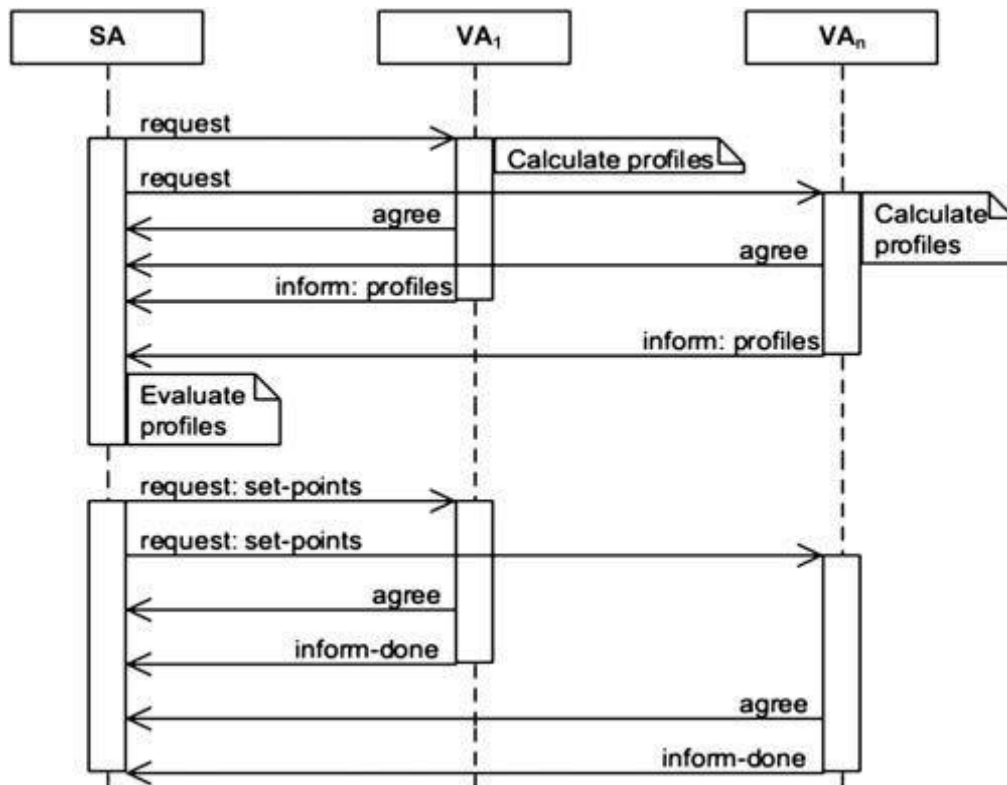

Figure 12.17 UML diagram of agent communication

The case study considers the case when the **SA** detects an overload on the transformer of the MV/LV substation. The policy examined is to avoid the violation of the loading limit which is assumed to be 700 kVA. The procedure followed is based on the FIPA Request Interaction Protocol and is shown in Unified Modeling Language (UML) notation in Figure 12.17.

- The **SA** initiates requests to the **VAs**.
- The **VAs** respond to the requests providing a number of possible charging schedules based on the EV owner preferences and the EV equipment characteristics.
- The **SA** evaluates the responses based on the loading limit and decides the charging profiles that need to be followed.

CYBER SECURITY

Cyber Security is vital to protect electrical infrastructure from cyber intrusion. Generation, Transmission and Distribution automation system collects operational information from dispersed locations on centrally located servers. This information exchange between centrally located servers and field equipment is achieved through various communications medium on open standards. These systems are also connected to corporate network for sharing energy information to different business model. The use of open standard and connectivity to public networks has exposed systems to cyber-attack. Cyber security is an important part of Smart Grid

With the introduction of information and communication technology in power sector and also applying the concepts of smart grid, the whole power sector is now available in the cyber space. This has exposed electricity sector to cyber-attacks.

Due to the interconnection of information networks increased number of entry points and paths are now available for potential adversaries and unauthorized users to disrupt electricity services. Power sector application like SCADA, WAMS, AMI, OMS that are using these information networks becomes vulnerable to the attack. Any attack on AMI, SCADA, and OMS may lead to commercial loss apart from breach of important information and jeopardize of controlling and monitoring operation of grid. For example any attack on centralized distribution monitoring system can cause power supply failure. A disruption to critical infrastructure/customers like Hospitals, Metro, and Railways etc. is of strategic concern.

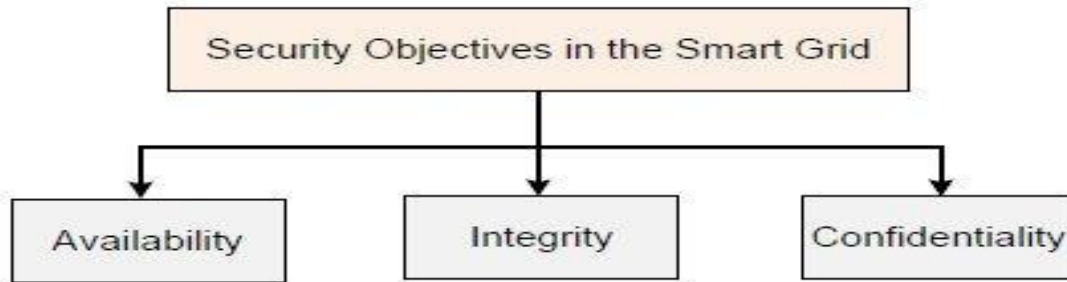

Cyber Security Requirements

To address cyber threats, security measures in smart grid are classified into following five (5) categories:

Availability: - Availability means information network are available for use by the appropriate parties in the manner intended. Availability of system is ensured by monitoring the ICT network at device level, communication level and at control centre end.

Authorization: Authorization is a security service that ensures that a party may only perform the actions that they're allowed to perform

Integrity: - Integrity assures that data/information cannot be altered in an unauthorized or malicious manner. Strong Point to point communication schemes are used to prevent spoofing and injection of false data.

Confidentiality:-means data/information is being protected from being disclosed to third party. Confidentiality of data and information is achieved by providing role based access at both data & information level and device level.

Authentication: - Authentication provides assurance that a party in data communication is who or what they claim to be.

Table 3: Comparison of security requirements between the Smart Grid and the Internet

Security Functions	Smart Grid Communication Network	The Internet
Authentication and access control	Strictly enforced for all communication flows throughout the system	Mostly free end-to-end without access control
Attack detection and countermeasures	Essential and widely-deployed everywhere	Mainly for critical routers and servers
Every node	Basic cryptographic functions	No specification
Security for network protocols	From MAC-layer to application-layer Security	From network-layer to application Layer Security

SMART GRID INFORMATION MODEL

Smart grid infrastructure comprises of metering and measurement device at field (ex. RTU & PMU in transmission. Meter, FPI, FRTU in distribution), Communication network for information exchange and Control centre to collect data & information and use it for intended operations. National Institute of Standards & Technology (NIST) reference model for smart grid is shown below.

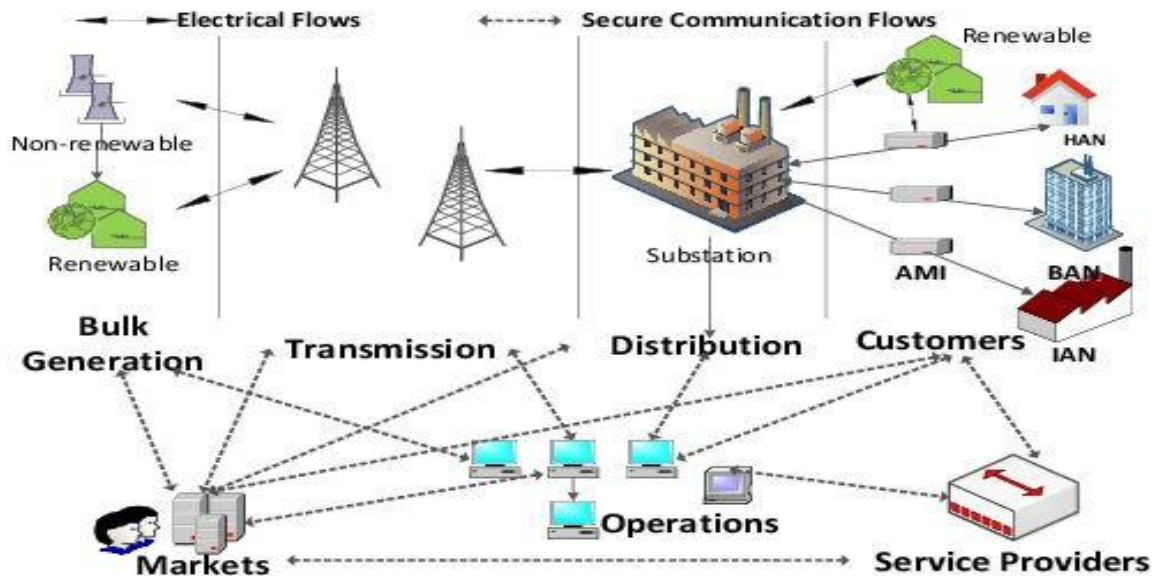

The information is exchanged at device level where it is generated, during exchange on communication network and at control centre where it is collected for intended use. Following measures will ensure security of data at different node:

i) Security at Device level

To ensure security at metering and measurement end device must have following features:

- Ability to make sure that control operations originate from an authorized control centre
 - Ability to identify that remote & local maintenance access is only granted to authorized users
 - Ensure that only authorized devices can connect to the communications network
 - Authentication through individual user accounts
 - The ability to assign functions and features based on the user account
 - An audit trail that lists events in the order they occurred
 - The ability to monitor security events & make the information available to control centres
 - A mechanism through which a control centre can grant or refuse access to a function or feature
- IEC 62351 standard security requirements and standard data transfer protocol for Smart Grid applications incorporate all above security provisions.

ii) Securing the communication link:

On communication link, connections are generally established on TCP/IP link using standard Point to Point (PPP) protocol with Hand shake Authentication (CHAP) authentication. Communication link can also be secured by setting up Virtual Private Network (VPN) to ensure the authenticity of both networks endpoints and the confidentiality of the data.

iii) Securing control centre

At control Centre end, the customer information is protected, with only authorized systems being allowed to access specific sets of data. Following standard IT security measures are used for ensuring security at control centre:-

Firewall Protection for Network: A technological barrier designed to prevent unauthorized access or unwanted communications between sections of a computer network. A firewall is a dedicated appliance or software running on a computer/ dedicated Hardware, which inspects network traffic passing through it, and denies or permits passage based on a set of rules. It is placed between a protected network (Control centre) and an unprotected network (users and field devices used to provide information) access and acts like a gate to protect assets to ensure that nothing private goes out and nothing malicious comes in.

Antivirus Protection: Anti-virus software keeps Viruses away from the system. They prevent the attack from several types of viruses such as Spyware, Adware, Trojans, Malware, and Worms. Without anti-virus protection, system are vulnerable to virus attack like changing registry settings to make all programs unusable, corrupting or removing vital system files to make the system unbootable, and change the user password to make it almost-impossible to login to your computer.

Apart from implementing required measures at all level following security checks should be carried out regularly to ensure that IT infrastructure is Cyber Secured.

- Regular third-party external and internal security audits
- Controlling endpoints
- Segment sensitive systems and information
- Auditing networks protection (policy, rules of network devices)
- Auditing web applications
- Searching for bad passwords
- Integrating security into every project plan
- Examining the policies of business partners
- Following a solid incident response plan

EE E19 - SMART GRID
TWO MARKS Questions & Answers

Unit-I

1. What is Smart Grid?

A **Smart Grid** is a digital electrical grid that facilitates the gathering and distribution of information with regard to the usage of power by suppliers and consumers. This will lead to electricity services becoming more reliable, efficient, cost-effective, and environmentally conscious.

Or

“A smart grid uses digital technology to improve reliability, security, and efficiency (both economic and energy) of the electric system from large generation, through the delivery systems to electricity consumers and a growing number of distributed-generation and storage resources.”

2. What are the advantages of Smart Grid Technology ?

- Peak leveling,
- Democratization of energy,
- Operational advantages including self-healing,
- other commercial benefits.
- Help businesses reduce their carbon footprint
- New opportunities for tech companies
- Reduce cost of power cuts.

3. Why implement the Smart Grid now?

Since about 2005, there has been increasing interest in the Smart Grid. The recognition that ICT offers significant opportunities to modernize the operation of the electrical networks has coincided with an understanding that the power sector can only be de-carbonized at a realistic cost if it is monitored and controlled effectively.

4. Write down the Enabling technologies or Attributes for the Smart Grid?

- *Information and communications technologies*
- Sensing, measurement, control and automation technologies
- Power electronics and energy storage.

5. What are the components of the Smart Grid?

- i) Smart Devices Interface Component
- ii) Storage Component
- iii) Transmission Subsystem Component
- iv) Monitoring and Control Technology Component
- v) Intelligent Grid Distribution Subsystem Component
- vi) Demand Side Management Component,

6. What is the smart grid vision for India ?

“Transform the Indian power sector into a secure, adaptive, sustainable and digitally enabled ecosystem that provides reliable and quality energy for all with active participation of stakeholders”

7. Write down any four of the ongoing Smart grid Projects?

APDRP, R-APDRP initiative for distribution reform (AT&C focus)

DRUM India – Distribution Reform Upgrade, Management

Four pilot sites (North Delhi, Bangalore, Gujarat, Maharashtra)

KEPCO project in Kerala

L&T and Telvent project – Maharashtra

8. What are the key features of the Smart Grid?

- i) Load Management
- ii) Demand Response support
- iii) Decentralization of Power generation

9. What is the concept of Virtual Power Plant (VPP)?

The concept of a Virtual Power Plant (VPP) is to aggregate many small generators into blocks that can be controlled by the system operator and then their energy output is traded.

Unit –II

1.What is the use of WAMS?

WAMS are designed by the utilities for optimal capacity of the transmission grid and to prevent the spread of disturbances. By providing real - time information on stability and operating safety margins, WAMS give early warnings of system disturbances for the prevention and mitigation of system - wide blackouts.

2.What is PMU?

A Phasor Management Unit A device –(microprocessor based unit) which reports the magnitude and phase angle of an analog and /or derived phasor with respect to the global time reference, as per the synchrophasor standards (IEEE 1344, IEEE C37.118).

3.Why is PMU important?

PMUs collect location, time, frequency, current, voltage and phase angle

- Large unexpected variability due to wind energy
- Can produce phase instability
- Results in poor decision making [ex: scheduling]
- Which can lead to big problems [ex: voltage instability, islanding, cascading failures]
- Directly provides the phase angles [from State Estimation to State Measurement]

4.What are the Basic differences from “conventional” measuring points at substation automation and PMU?

Sl.No	Measured Values from Sub-Station Automation Systems	Synchrophasor from PMU
1	Slower updating Cycle (e.g. once every 5 Sec)	Continuous updating (e.g.10 Values per sec)
2	Measured Values without time stamp	Each measured value with precise time Stamp
3	RMS values without Phase angle	Current and voltage are supplied as a vector value with amplitude and phase

– Distribution Management System roll-out

5. Draw the important elements of the overall PMU system..

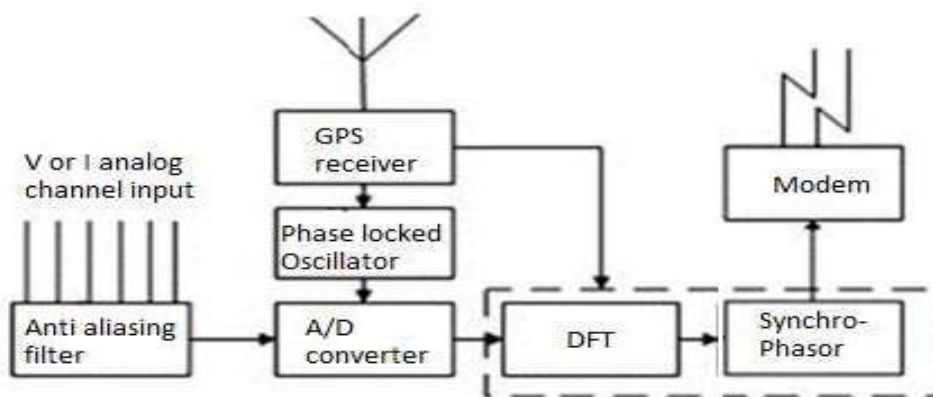

6. What is the use of IED?

Intelligent Electronic Devices (IED) to provide advanced protective relaying, measurements, fault records and event records for the power system.

7. What are the Benefits of Smart Grid?

Reduction in electricity bill amount of consumers

Reduced operations and maintenance costs.

Improved reliability & quality

Improved system security

Consumer's Participation in energy management

8. Write down the Enabling technologies or Attributes for the Smart Grid?

- a. *Information and communications technologies*
- b. Sensing, measurement, control and automation technologies
- c. Power electronics and energy storage.

9. What are the features of the Smart Grid?

- Be able to self heal
- Motivate consumers to actively participate in operations of the grid
- Resist attack or hacking
- Provide higher quality power that will save power wasted from outages
- Accommodate all generation and storage option
- Enable electricity markets to flourish

10. What is PDC?

Phasor data concentrator is placed at central location to gather data from several PMUs, reject bad data and time aligned the time stamped data to create a synchronized data set and transmit this data set to other information system.

11. Write down the four file types of Synchrophasor standard?

- Header files,
- Configuration files,
- Data files. One file,
- Command File.

12. What is 'SOC' and FRACSEC?

A 4-byte **Second Of Century (S.O.C)** time tag counts the number of seconds that have occurred as an unsigned 32-bit Integer. ,

A 3-byte **Fraction of Second** is one second can be broken down into 16, 777,216 counts or about 59.6 n sec/count.

13. How will you choose the sampling rate in anti-aliasing filters?

The sampling rate chosen for the sampling process dictates the frequency response of the anti-aliasing filters. In most cases these are analog-type filters with a cut-off frequency less than half the sampling frequency in order to satisfy the Nyquist criterion.

14. What is NAPI?

NASPI (North American SynchroPhasor Initiative) brings together the utility industry, manufacturers and vendors, academia, national laboratories, government experts and standards-making bodies. This large volunteer community dedicated to synchrophasor technology advancement has collaborated to address and solve technical, institutional, standards development, and other strategic issues and obstacles.

15. Write down some of the corrective & emergency control actions in Blackout Prevention.

- Under-frequency load shedding
- Generator rescheduling and voltage control
- Transformer Tapping
- FACTS control
- Unstable device tripping
- System islanding

UNIT-III

1. What are the key components of AMI?

- Smart Meter
- Two Way Communication Network,
- Home Area Network (HAN)
- Data Concentrator Unit (DCU),
- Meter Data Management System (MDMS),
- Utility Data Centre.

2. What is MDMS?

MDMS is the heart of AMI systems. MDM application analyses the meter data along with GIS mapping and consumer indexing. It facilitates Billing, Collection, Energy Accounting, Load Research, Load management etc. The Customer Portal and many other utility/consumer centric applications depend on the data & insight generated by MDMS.

3. What is SCADA?

A SCADA (Supervisory Control and Data Acquisition System) system gathers information (such as voltage, current, CB status, operation of relay during fault, etc.), transfers the information to central host computer, that fault has occurred, carry out control and necessary action, and display the information in a logical and organized fashion.

4. What is the use of Fault Passage Indicators(FPI)?

Fault Passage Indicators identifies location / type of faults through visual indications at control centre. The Identification of section under fault is used to direct maintenance crew for quick recovery of faulty section for subsequent restoration of faulty part.

5. What is mean by Peak Load Management?

The PLM application collects information from various systems like the load forecast, SCADA, and MDM sub systems. Based on these inputs power demand-supply is determined for present and the next time block and the deficit/surplus is worked out. Based on the deficit/surplus demand response / demand side management signals are sent out to the consumers.

6. What is WAN , NAN and HAN?

Wide area network (WAN) connects AMI network with utility network on private or public network.

Home Area Network (HAN):

A Home-Area Network (HAN) is an integrated system of smart meter, in-home display, micro- generation, smart appliances, smart sockets, HVAC facilities and plug-in hybrid/electric vehicles.

Neighborhood Area Network (NAN): The neighborhood area network is a network which is comprised of neighboring smart meters. A collector in NAN takes charge of the aggregation of metering data from smart meters, and the popular WiFi technology is suggested for NAN.

7. What are the Communications used in Smart meters?

Public Switched Telephone Network (PSTN),
Power line carrier
Ethernet
ZigBee,
Infrared,
GSM /CDMA /GPRS

8. What are the Features of Smart meter systems?

- i. Information on energy consumption
- ii. Customer supply contracts
- iii. Running energy businesses better
- iv. Multi-utilities
- v. Renewable and distributed generation

9. Define Prosumer.

Customers who produce electricity primarily for their own needs, but can also sell the excess electricity. Prosumers are connected to the distribution network with small to medium installed capacity.

10. What are the basic types of Smart meter?

There are two basic categories of Smart Meter system technologies as defined by their LAN. They are

- i) Radio Frequency (RF)
 - a) Mesh Technology
 - b) Point-to-Point Technology
- ii) Power Line Carrier (PLC).

UNIT-IV

1. What is meant by Modem?

A modem (modulator-demodulator) is a network hardware device that modulates one or more carrier wave signals to encode digital information for transmission and demodulates signals to decode the transmitted information. The goal is to produce a signal that can be transmitted easily and decoded to reproduce the original digital data.

2. Write down the different modulation techniques used in Smart grid?

Common analog modulation techniques are: Amplitude modulation (AM), Frequency modulation (FM), Phase modulation (PM). In digital modulation, an analog carrier signal is modulated by a discrete signal. Basic keying techniques are: PSK (phase-shift keying), FSK (frequency-shift keying), ASK (amplitude-shift keying), and QAM (quadrature amplitude modulation).

3. What is OFDM?

Orthogonal Frequency division Multiplexing (OFDM) is another digital multi-carrier modulation scheme that uses a large number of closely spaced orthogonal subcarriers to carry data. Each subcarrier is modulated with a conventional modulation scheme at a low symbol rate, maintaining data rates similar to conventional single carrier modulation schemes in the same bandwidth.

4. Define GPRS?

GPRS stands for the General Packet Radio Service. It is a packet-based wireless communications service, based on GSM (which is circuit based) communication, and is recognized in the business as the best platform for mobile data networking services.

5. How will you classify the GPRS supporting devices?

- i) **Class A devices** which can be connected to GPRS service and GSM service (voice, SMS), using both at the same time.
- ii) **Class B devices** which can be connected to GPRS service and GSM service (voice, SMS), but using only one or the other at a given time.
- iii) **Class C devices** are connected to either GPRS service or GSM service (voice, SMS). Such devices must be switched manually between services.

6. What is DLMS?

Device Language Message Specification (DLMS) is a generalized concept for abstract modeling of communication entities; basically it is a messaging method providing an interface between the COSEM objects and the communication protocols.

7. What are the advantages of IP Version 6?

IP version 6, also known as IP Next Generation is a 128 bit addressing scheme and supports a virtually unlimited number of devices - 2 to the 128th power.

Advantages:

i) Internet Protocol Security (IPsec) is mandatory for IPv6. It is a protocol suite for securing Internet Protocol (IP) communications by authenticating and encrypting each IP packet of a communication session.

ii) Support for jumbograms which can be as large as 4, 294, 967, 295 (2³² -1) octets. In contrast, IPv4 supports datagrams upto 65, 535 (2¹⁶-1) octets.

8. What is the principle of Power Line Communication?

The principle of PLC is that a high frequency information signal is added ('modulated') to the 50Hz power flow signal ('carrier signal') at the sending end and is removed at the receiving end('de-modulated').

9. What is the disadvantage of Zigbee Technology?

Low processing capabilities, small memory size and small delay requirements are subjected to interference with other industrial appliances. The obstacle between two meters should be minimum. Meters should not be installed in metal enclosure.

10. State the frequency range for Radio Communication?

Radio communications may be multipoint or point-to-point, operating typically either at UHF frequencies (between 300 MHz & 3 GHz) (or microwave frequencies between 3 & 30 GHz)

UNIT-V

1. What is HAN?

A home area network (HAN) is a network that is deployed and operated within a small boundary, typically a house or small office/home office (SOHO). It enables the communication and sharing of resources (like the Internet) between computers, mobile and other devices over a network connection.

2. What is GOOSE?

Generic Object Oriented Substation Events (GOOSE) is a communications control model mechanism in which any format of data (status, value) is grouped into a data set and

transmitted where processing by the receiver must take place within 4 ms. The speed of the data transfer creates the potential to replace protection, control and monitoring substation automation functions typically served by conventional point-to-point copper wiring between:

- a relay and the primary equipment – e.g. reclosing
- relay to relay – e.g. breaker trip coordination
- a relay and the bay control unit – e.g. interlocking

3. What are the two options used in HAN services in demand side management?

In order to provide demand management functions and demand response, two options are being actively considered in different countries. One option is to use the smart meter as the interface to the suppliers, network operators and other actors. The other option is to use a separate control box which is directly interfaced to the outside world through the NAN and WAN.

4. What is PHEV and write down the benefits.

PHEV -

The benefits of PHEVs are largely similar to those of electric vehicles in that they can, if kept at a high level of charge, operate the majority of the time on electric power, thus reducing their emissions to zero at the point of use.

5. Write down the types of PHEV?

Types by nature of the power source

1. Electric-internal combustion engine hybrid
2. Fuel cell hybrid
3. Human power and environmental power hybrids
4. Pneumatic hybrid
5. Hydraulic hybrid

6. What are the advantages & disadvantages of PHEV?

Advantages

- Improvements in fuel consumption
- Reduction of in-use emissions – potentially to zero
- Cheap to run

Disadvantages

- High capital cost
- Lack of availability
- Limited range in some types
- Emissions can simply be transferred to production sources

7. What is the difference between conventional capacitor to Super capacitor?

Supercapacitors store charge in a similar way to conventional capacitors, but the charge does not accumulate in two conductors, but in the interface between the surface of a conductor and an electrolytic solution.

8. What are the principle technologies used in Super capacitors?

. Two principal technologies are used:

- i) Aqueous (maximum voltage of 1.2 V and work voltage of 0.9 V)
- ii) Organic (voltage near 3 V but with a much higher series resistance).

9. Write down the different types of Super capacitors.

- i) Double-layer capacitors - with carbon electrodes or derivate with much higher static double-layer capacitance than the faradic pseudo-capacitance
- ii) Pseudo-capacitors - with electrodes out of metal oxides or conducting polymers with a high amount of faradic pseudo-capacitance
- iii) Hybrid capacitors - capacitors with special and asymmetric electrodes that exhibit both significant double-layer capacitance and pseudo-capacitance, such as lithium-ion capacitors

10. Write down the Advantages of Super capacitors over Batteries?

Advantages Over Batteries

- Power density
- Recycle ability
- Environmentally friendly
- Safe
- Light weight

11. Write down the Applications of Super capacitors.

Applications for Supercapacitors

- Computer systems - Power generators
- UPS systems - Battery assist
- Power conditioners - Smart meters
- Welders - Energy harvesting
- Inverters - Medical systems
- Automobile brakingsystems - Audio systems
- Power supplies - Emergency lighting
- Cooking equipment - Electric valves/ solenoids

12. What is SMES?

. A Superconducting Magnetic Energy Storage system stores the energy as magnetic energy in a superconducting magnet cryogenically cooled, achieving a system with negligible losses. The AC energy is stored as DC energy and brought back from DC to AC energy from the superconducting magnet by a reversible AC/DC Power Converter Module (PCM).

13. What are the main parts of SMES?

A typical SMES system includes three parts:

- i) Superconducting coil,
- ii) Power conditioning system and
- iii) Cryogenically cooled refrigerator

14. What are the disadvantages of SMES?

The main disadvantage of the SMES system is that the energy density is low and there is a need for a criogenization system that could be very complex for large scale application. A possible solution is to combine them in hybrid ESS increasing their energy and power.

15. What are the features of SMES?

Features of SMES

- Capability of absorbing and delivering large amounts of power.
- High efficiency.
- Long lifetime.

- Short response time.
- Completely static construction, low maintenance.
- All electric energy storage

16. Write down the Applications of Energy Storage Systems.

- i) Power Quality
- ii) Service provision to renewable generation
- iii) Electrical Energy time shifting
- iv) End use energy management
- v) Voltage Support
- vi) Reserve
- vii) Load following

17. What is advantage and uses of the Nickel Cadmium Battery?

The robust nature of technology, combined with its energy density, gives it advantages over lead acid.

Nickel Cadmium (NiCd) batteries are extensively used for power tools, mobile phones and laptops.

18. What is Flow Battery and write down its Applications.

Flow Battery

Applications

- [Loadbalancing](#)
- Storing energy from renewable sources
- Peak shaving, where spikes of demand are met by the battery.
- [UPS](#), where the battery is used if the main power fails to provide an uninterrupted supply.
- [Power conversion](#) – because all cells share the same electrolyte/s.
- [Electric vehicles](#) – Because flow batteries can be rapidly "recharged"
- [Stand-alone power system.](#)

19. What is Fuel cell and write down its types?

A fuel cell is a device that converts chemical energy directly into electrical energy. However, unlike batteries, with non-stop supply of fuels, fuel cell can run forever and produce steady supply of electrical energy. The two basic components used to run a fuel cell are hydrogen and oxygen.

There are five major types of fuel cells being known or used in the market..

- ◆ Alkaline Fuel Cell (AFC)
- ◆ Phosphoric Acid Fuel Cell (PAFC)
- ◆ Molten Carbonate Fuel Cell (MCFC)
- ◆ Solid Oxide Fuel Cell (SOFC)
- ◆ Proton Exchange Membrane Fuel Cell (PEMFC)

20. Write down its applications of Fuel Cell.

APPLICATIONS

- Space Exploration
- Transportation
- Stationary and Residential Applications
- Portable Power for Electronics
- [Distributed generation](#)
- [Emergency power systems](#)
- [Hybrid vehicles](#),
- [Smart phones](#), laptops and tablets.

21. What is Flywheel and write down the applications?

A flywheel is a rotating mechanical device that is used to store [rotational energy](#). Flywheels have an inertia called the [moment of inertia](#) and thus resist changes in rotational speed. The amount of energy stored in a flywheel is proportional to the square of its [rotational speed](#). Energy is transferred to a flywheel by the application of a [torque](#) to it, thereby increasing its rotational speed, and hence its stored energy.

Flywheels are used in Buses, Cars, Container Cranes, Construction Machines, Garbage Trucks, Charging Stations, Train Stations, Trams, Micro-Grid Stabilization and Power Quality.

22. What is Substation Agent (SA) and Vehicle Agent (VA)?

i). The Substation Agent (SA) is located at the secondary substation at the MV/LV level. It is responsible for managing the battery charging/discharging of the electric vehicles within a LV area.

ii). The Vehicle Agent (VA) is located at the vehicle and represents an EV owner or an EV Aggregator. It is responsible for managing the charging/discharging of an individual EV or fleet of EVs.

23. What are the Cyber Security requirements or objectives in Smartgrid?

- i) Availability
- ii) Authorization
- iii) Integrity
- iv) Confidentiality
- v) Authentication

24. What is Cyber Security?

Cyber security is a concept that has become increasingly prevalent with the development of the smart grid technology with the increased use of digital information and controls technology to improve reliability, security, efficiency of the electric grid and the deployment of smart technologies (real - time, automated, interactive technologies that optimize the physical operation of appliances and consumer devices) for metering, communications concerning grid operations and status, and distribution automation.

25. What are the standard IT security measures for ensuring security at control centre?

- i) Firewall Protection for Network
- ii) Antivirus Protection

26. Write down some security checks to ensure IT infrastructure is Cyber Secured.

- Regular third-party external and internal security audits
- Controlling endpoints
- Segment sensitive systems and information
- Auditing networks protection (policy, rules of network devices)
- Auditing web applications
- Searching for bad passwords
- Integrating security into every project plan
- Examining the policies of business partners
- Following a solid incident response plan

27. What is Interoperability?

Interoperability is “The ability of two or more systems or components to exchange Information and to use the information that has been exchanged.”